

WL2803E

Ultra low dropout, 500mA, CMOS LDO

[Http://www.ovt.com](http://www.ovt.com)

Descriptions

The WL2803E series are ultra low dropout, Low quiescent current, high PSRR CMOS LDO. The dropout voltage is 130mV (Typ.) at 500mA load current.

Using CMOS construction, the quiescent current consumed by the WL2803E is typically 150uA over the entire input voltage range, making it attractive for consumer, networking applications that demand high output current. The WL2803E series are available in wide output voltage range version from 1.2V to 3.3V with 0.1V step.

The WL2803E series offer thermal shutdown (OTP) and current limit functions, to assure the stability of chip and power system at wrong condition, and it uses trimming technique to guarantee output voltage accuracy within $\pm 2\%$.

The WL2803E regulators are available in SOT-23-5L packages. Standard products are Pb-free and Halogen-free.

Features

- Input voltage : 2.5V~5.5V
- Output voltage : 1.2V~3.3V
- Output current : 500mA
- PSRR : 65dB @ 1KHz
- Dropout voltage : 130mV @ $I_{OUT}=0.5A$
- Output noise : 100uV
- Quiescent current : 150 μ A Typ.

Applications

- LCD TV
- STB
- Computer, Graphic card
- Network communication equipments
- Others portable electronics devices



SOT-23-5L

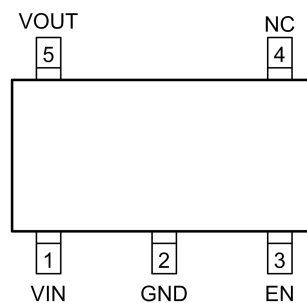

Pin Configuration (Top View)

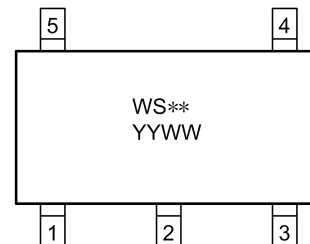

WS = Device code
 ** = Voltage code (33: 3.3V)
 YY = Year code
 WW = Week code

Marking

Order Information

For detail information, Please refer to page 9.

Typical Application

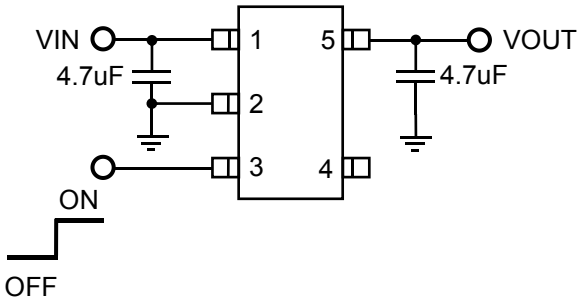

Pin Description

PIN	Symbol	Description
1	VIN	Input
2	GND	Ground
3	EN	Enable, Active High
4	NC	Not connect
5	VOUT	Output

When the output is less than 2V, it is recommended that the Cout is more than 10uF.

Block Diagram

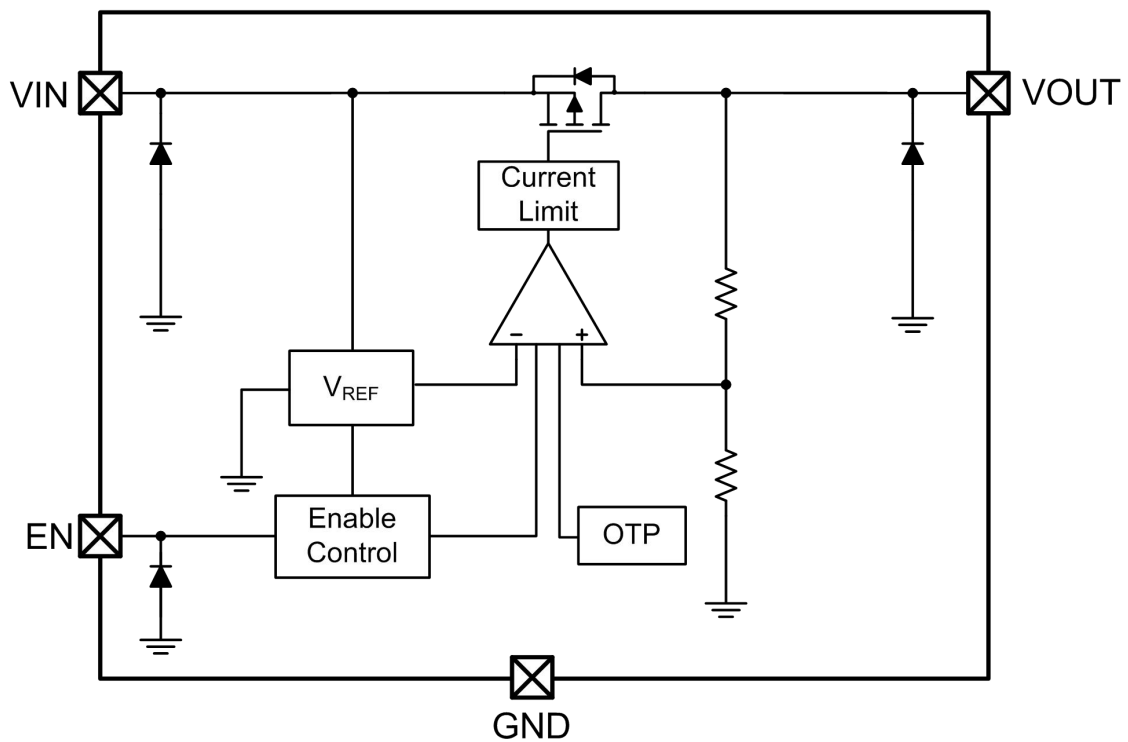

Absolute Maximum Ratings

Parameter	Symbol	Value	Unit
Input voltage range	V_{IN}	-0.3~6.5	V
Output voltage range	V_{OUT}	-0.3~ V_{IN}	V
Power dissipation *1 *3	P_D	0.7	W
Power dissipation *2 *3		0.5	W
Thermal resistance *1	$R_{\theta JA}$	180	°C/W
Thermal resistance *2		250	°C/W
Junction temperature	T_J	150	°C
Lead temperature(10s)	T_L	260	°C
Storage temperature	T_{stg}	-55 ~ 150	°C
ESD Ratings	HBM	±8000	V
	MM	±400	V

Note: These are stress ratings only. Stresses exceeding the range specified under “Absolute Maximum Ratings” may cause substantial damage to the device. Functional operation of this device at other conditions beyond those listed in the specification is not implied and prolonged exposure to extreme conditions may affect device reliability.

*1: Surface mounted on FR-4 Board using 1 square inch pad size, dual side, 1oz copper

*2: Surface mounted on FR-4 board using minimum pad size, 1oz copper

*3: Power dissipation is calculate by $P_D = (V_{IN}-V_{OUT}) \times I_{OUT}$

Recommend Operating Ratings

Parameter	Symbol	Value	Unit
Operating Supply voltage	V_{IN}	2.5~5.5	V
Operating Temperature Range	T_{opr}	-40~85	°C

Electronics Characteristics (Ta=25°C, V_{IN}=V_{OUT}+1V, C_{IN}=C_{OUT}=4.7uF, unless otherwise noted)

Parameter	Symbol	Condition	Min.	Typ.	Max.	Unit
Output Voltage	V _{OUT}	V _{OUT} < 1.5V, V _{IN} =2.5V, I _{OUT} =1mA	V _{OUT} - 30mV	V _{OUT}	V _{OUT} + 30mV	V
		V _{OUT} ≥ 1.5V, I _{OUT} =1mA	V _{OUT} * 0.98	V _{OUT}	V _{OUT} * 1.02	
Dropout Voltage	V _{DROP}	V _{OUT} =V _{OUT} *0.98, I _{OUT} =500mA		130	230	mV
Current Limit	I _{LIM}	V _{IN} =5V	0.65			A
Line Regulation	ΔV _{LINE}	V _{OUT} =3.3V, V _{IN} =4.3~6.0V, I _{OUT} =1mA		5	10	mV
Load Regulation	ΔV _{Load}	V _{OUT} =3.3V, I _{OUT} =1~500mA		10	30	mV
Quiescent Current	I _Q	V _{OUT} =3.3V, I _{OUT} =0		150	200	uA
Shut-down Current	I _{SHDN}	V _{EN} = 0V		0.1	1.0	uA
Power Supply Ripple Rejection	PSRR	V _{IN} =(V _{OUT} +1V) _{DC} +0.2V _{P-P} F=1KHz, I _{OUT} =10mA		65		dB
		V _{IN} =(V _{OUT} +1V) _{DC} +0.2V _{P-P} F=10KHz, I _{OUT} =10mA		58		
Output noise voltage	e _{NO}	10Hz to 100KHz, C _{OUT} =4.7μF		100		μV _{P-P}
EN logic high voltage	V _{ENH}	V _{IN} =5.5V, I _{OUT} =1mA	1.2			V
EN logic low voltage	V _{ENL}	V _{IN} =5.5V, I _{OUT} =0mA			0.4	V
Thermal shutdown threshold	T _{SD}			165		°C
Thermal shutdown hysteresis	Δ T _{SD}			30		°C

Typical characteristics ($T_a=25^\circ\text{C}$, $V_{IN}=V_{OUT}+1\text{V}$, $C_{IN}=C_{OUT}=4.7\mu\text{F}$, unless otherwise noted)

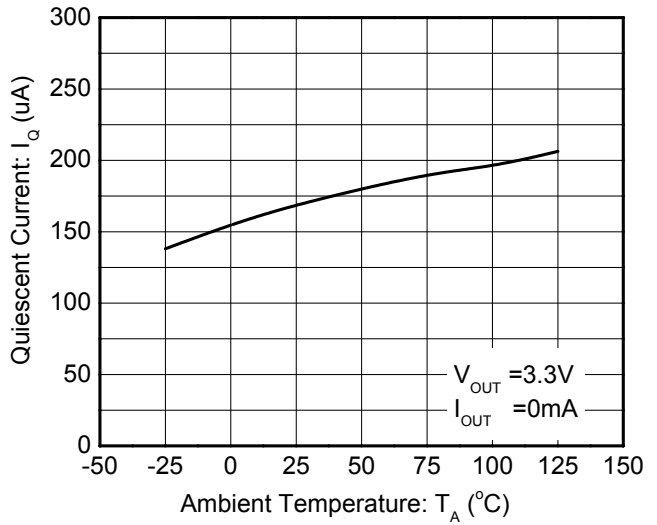
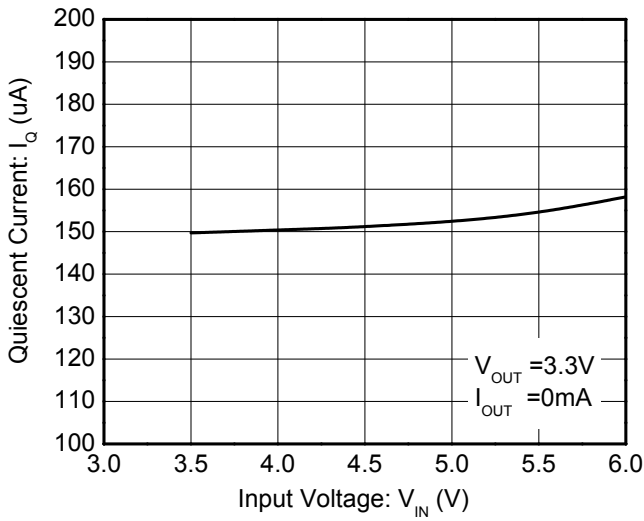

Quiescent current vs. Supply voltage

Quiescent current vs. Ambient temperature

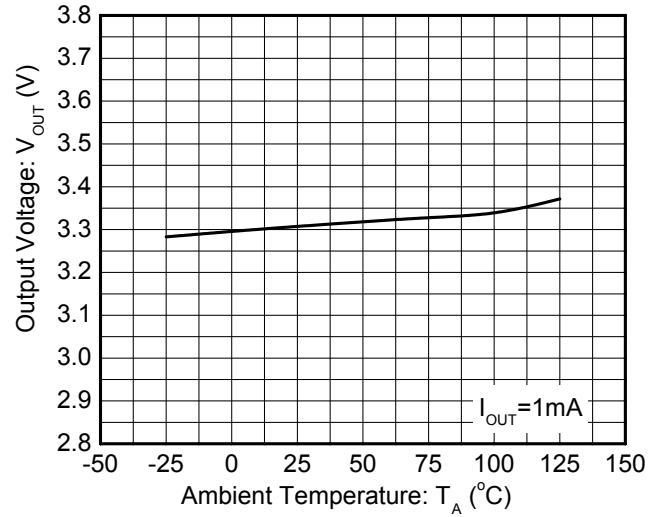
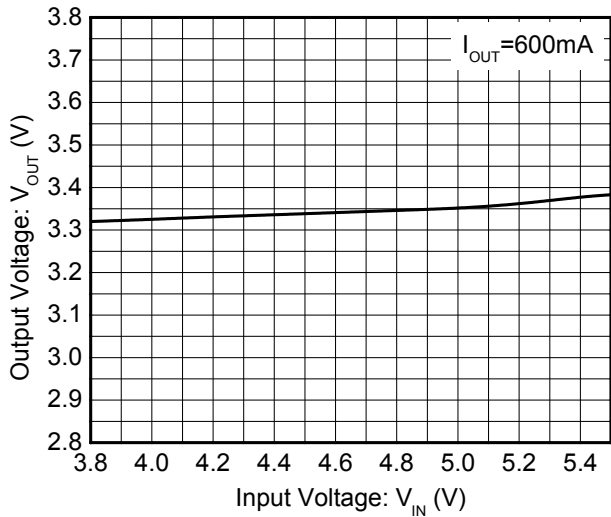

Output voltage vs. Supply voltage

Output voltage vs. Ambient temperature

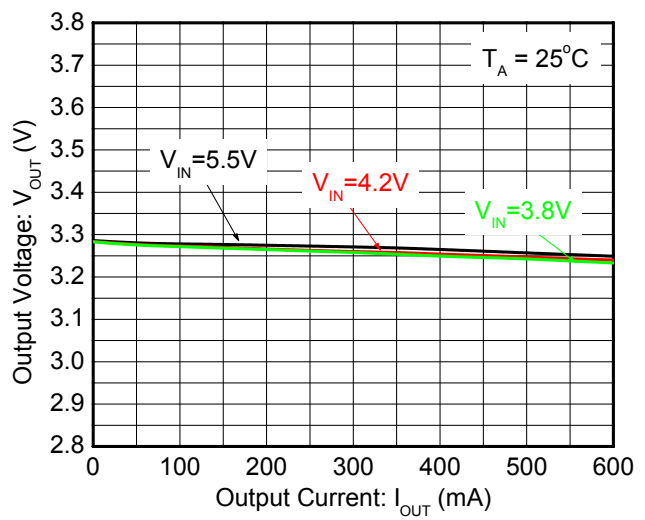
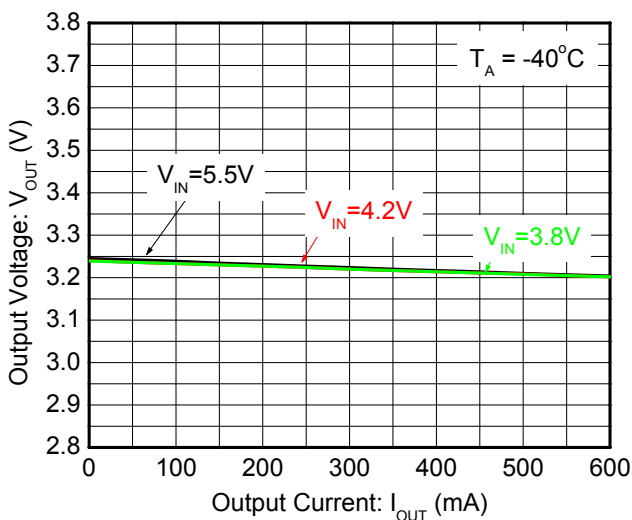

Output voltage vs. Output current

Output voltage vs. Output current

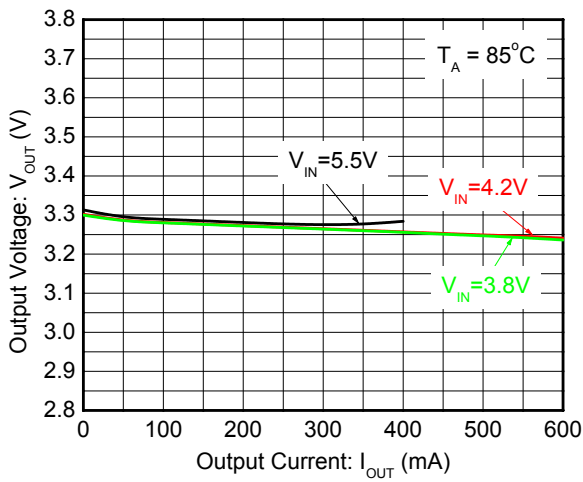

Output voltage vs. Output current

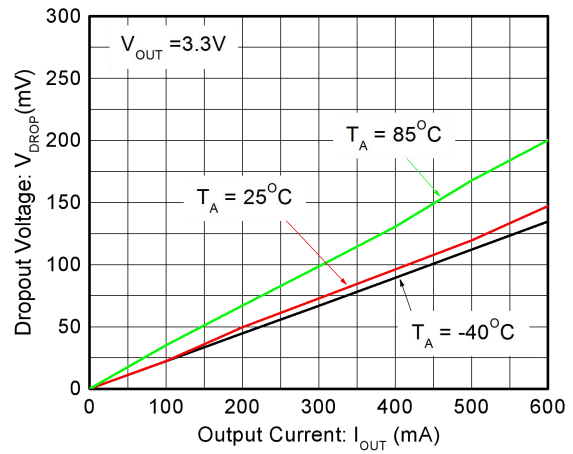

Dropout voltage vs. Output current

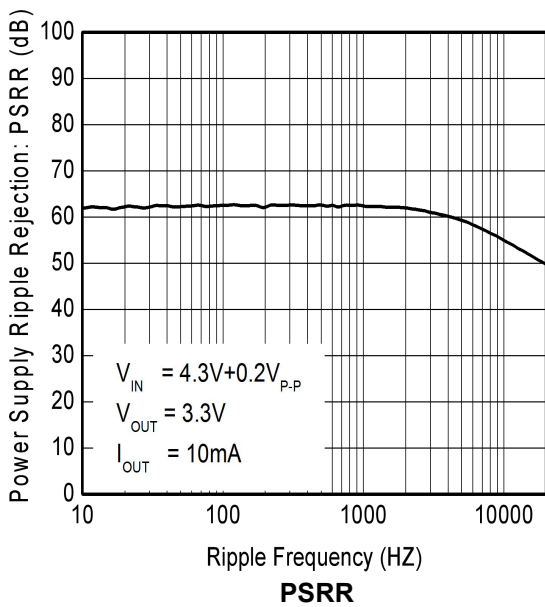

PSRR

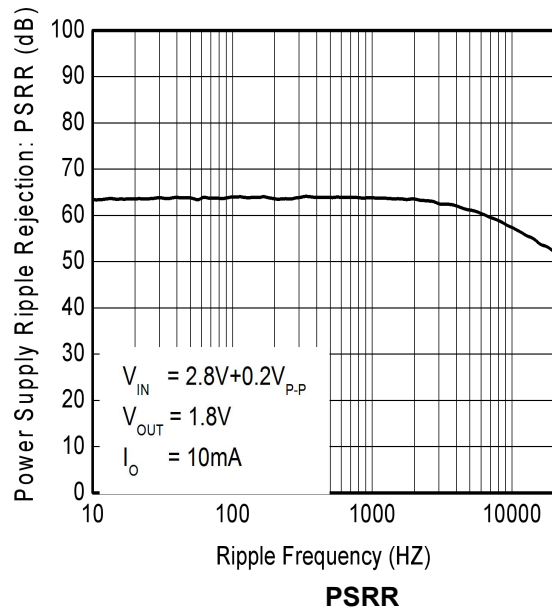

PSRR

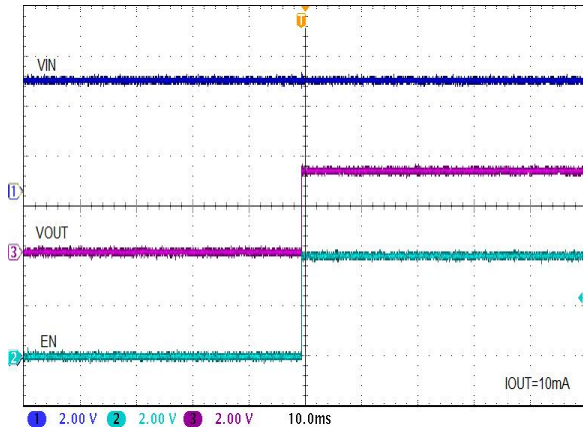

Startup with EN

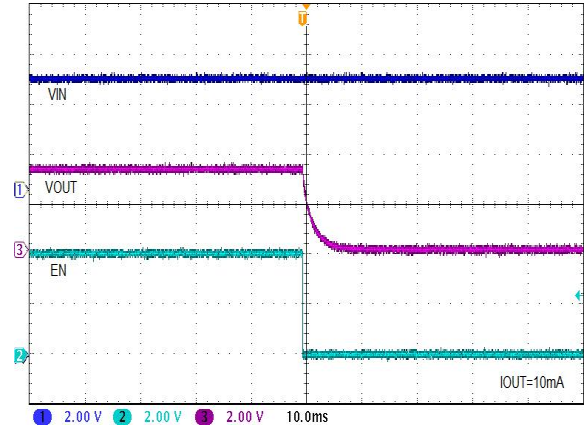

Shutdown with EN

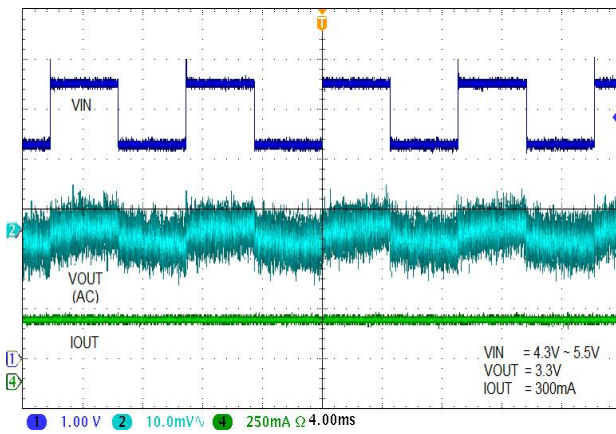

Line Regulation

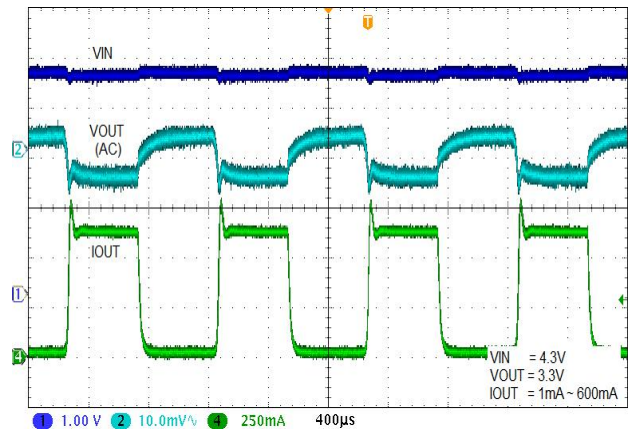

Load Regulation

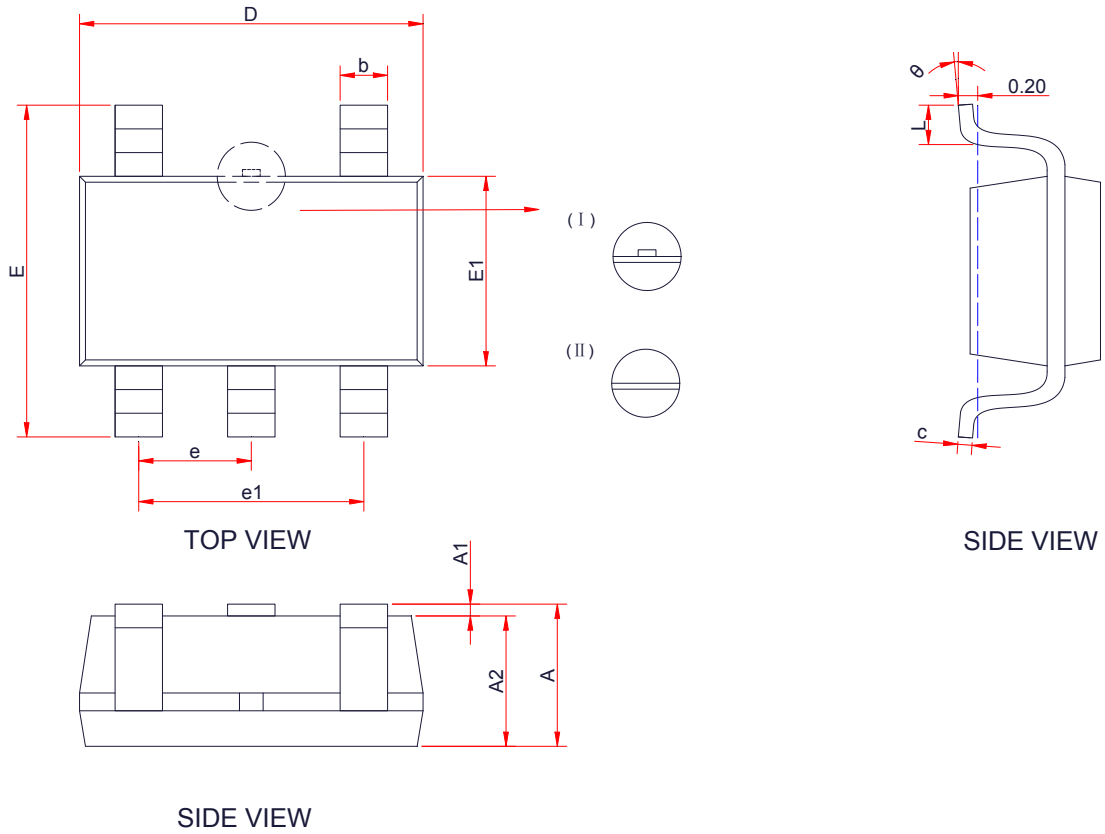
Package outline dimensions
SOT-23-5L

Symbol	Dimensions in Millimeters		
	Min.	Typ.	Max.
A	-	-	1.45
A1	0.00	-	0.15
A2	0.90	1.10	1.30
b	0.30	0.40	0.50
c	0.10	-	0.21
D	2.72	2.92	3.12
E	2.60	2.80	3.00
E1	1.40	1.60	1.80
e	0.95 BSC		
e1	1.90 BSC		
L	0.30	0.45	0.60
θ	0°	-	8°

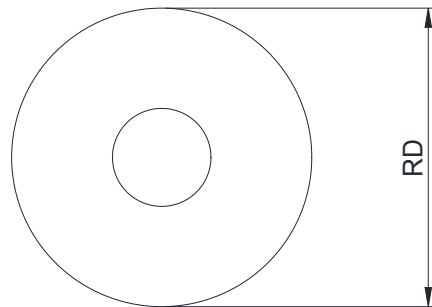
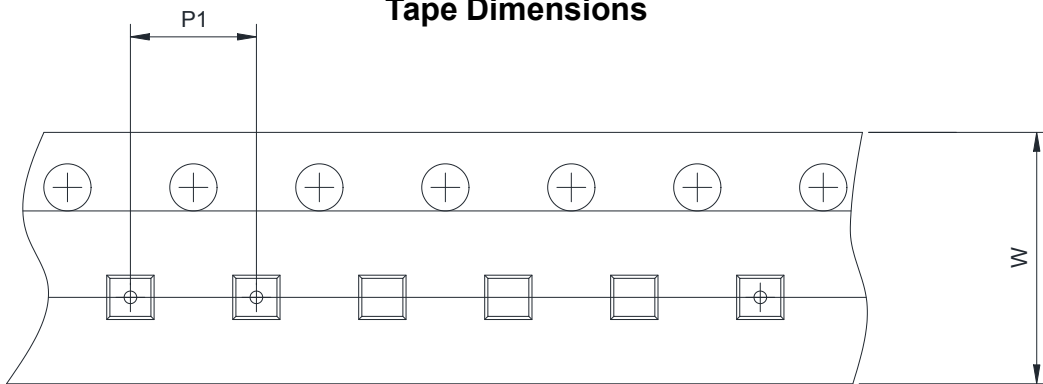
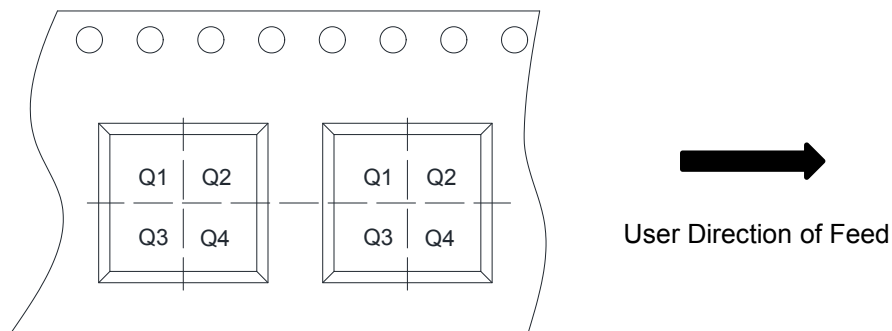
TAPE AND REEL INFORMATION
Reel Dimensions

Tape Dimensions

Quadrant Assignments For PIN1 Orientation In Tape

RD	Reel Dimension	<input checked="" type="checkbox"/> 7inch	<input type="checkbox"/> 13inch
W	Overall width of the carrier tape	<input checked="" type="checkbox"/> 8mm	<input type="checkbox"/> 12mm <input type="checkbox"/> 16mm
P1	Pitch between successive cavity centers	<input type="checkbox"/> 2mm	<input checked="" type="checkbox"/> 4mm <input type="checkbox"/> 8mm
Pin1	Pin1 Quadrant	<input type="checkbox"/> Q1	<input type="checkbox"/> Q2 <input checked="" type="checkbox"/> Q3 <input type="checkbox"/> Q4

ORDER INFORMATION

Ordering No.	V_{OUT} (V)	Package	Marking	Operating Temperature	Shipping
WL2803E12-5/TR	1.2	SOT-23-5L	WS12/YYWW	-40 ~ +85°C	3000/Tape and Reel
WL2803E18-5/TR	1.8	SOT-23-5L	WS18/YYWW	-40 ~ +85°C	3000/Tape and Reel
WL2803E25-5/TR	2.5	SOT-23-5L	WS25/YYWW	-40 ~ +85°C	3000/Tape and Reel
WL2803E28-5/TR	2.8	SOT-23-5L	WS28/YYWW	-40 ~ +85°C	3000/Tape and Reel
WL2803E30-5/TR	3.0	SOT-23-5L	WS30/YYWW	-40 ~ +85°C	3000/Tape and Reel
WL2803E33-5/TR	3.3	SOT-23-5L	WS33/YYWW	-40 ~ +85°C	3000/Tape and Reel