



OA805

ASIC product brief

4K Video Processor with Industry's Lowest Power Consumption and HEVC Compression Capability for Battery-Powered Security and Surveillance Applications

OMNIVISION's OA805 is a video processor that supports high-efficiency video coding (HEVC) compression with the lowest power consumption in the industry. This advanced video compression standard reduces storage requirements and enables the streaming of 4K videos over wireless connections. The OA805 is extremely power efficient, and is making HEVC possible for battery-powered security cameras and video doorbells for the first time. Together with the industry's fastest boot-up time of 0.1 seconds, the OA805 allows designers to incorporate leading-edge performance into products that their customers can quickly and easily install anywhere, and never miss a thing. Furthermore, because the processor consumes no power when it is off, the overall power consumption of the security camera is extremely low and allows the camera to have up to two years of battery life.

The OA805 is a system-on-chip (SoC) featuring dual embedded Arm® Cortex® A5 CPU cores with Neon™ technology for accelerated

audio and video encoding/decoding, along with image processing, video encoding hardware and RGB/IR processing. Its high dynamic range (HDR) processing capability allows the OA805 to accept input from RGB/IR image sensors and support high-quality displays, for videos taken during the day or at night, in conditions with widely contrasting bright and dark images.

This video processor accepts up to 16 megapixel captures from an image sensor and outputs up to 4K resolution video at 30 frames per second (fps) using HEVC encoding and decoding. It also supports multiple video streams at lower resolution, including H.264 1080p resolution at 60 fps, as well as HDR and RGB-IR.

Find out more at www.ovt.com.

Arm® and Cortex® are the registered trademarks of Arm Limited (or its subsidiaries) in the US and/or elsewhere. NEON™ is the trademark of Arm Limited (or its subsidiaries) in the US and/or elsewhere.



Applications

- battery-powered smart home monitoring camera applications

Technical Specifications

- power supply:**
 - core: 0.9V
 - analog: 1.8V / 3.3V
 - DDR I/O: 1.2V (LPDDR2) / 1.35V (DDR3L) / 1.5V (DDR3)
 - I/O: 1.8V / 3.3V
 - PLL: 1.8V
 - EFUSE VPP: 1.8V
- temperature range:**
 - commercial grade operational temperature: -30°C to +85°C
- package dimensions:** 11 mm x 11 mm

Product Features

- general features**
 - highly integrated low power and fast boot up video processor
- camera interfaces**
 - MIPI one 4-lane or two 2-lane receiver
 - supports up to 16 Mpixel image sensor
 - SCCB master to access image sensor
- image signal processor**
 - dual sensor 10-bit raw to YUV processing
 - adjustable AEC/AGC, AWB and auto focus
 - color correction/adjustment, gamma correction and contrast adjustment
 - digital effects
 - 16x16 zone lens shading correction and online color shading correction
 - lens distortion and perspective correction
 - defective pixel correction
 - mirror, flip and rotation
 - supports up to 4X digital zoom
 - 3D/2D de-noise filter
 - RGB-IR processing
 - HDR processing
- still picture**
 - supports still picture capture up to 16MP
 - supports still picture compression
- video engine**
 - supports single video recording with a maximum resolution of up to 4096 x 2160
 - supports dual video stream recording with one 1920 x 1080 stream and one 1280 x 720 stream
 - rate control to support variable and constant bit rates
 - flexible motion detection with 8 windows of ROI
- storage interfaces**
 - one storage card peripheral interface
 - two storage IO peripheral interfaces
 - NAND flash interface
- USB device**
 - USB2.0 HS/FS device controller
 - supports UVC video class
 - supports mass storage class
- security engine**
 - supports AES/DES/3DES encryption/decryption
 - supports secure boot with firmware image authentication and allowing JTAG accesses to authenticated users
- audio interface**
 - supports external audio CODEC through two audio serial interfaces for full duplex audio functions
 - embedded audio engine for audio recording and playback
 - supports various audio formats
- display interface**
 - supports MIPI two-lane transmitter
 - supports 10-bit DVP output
 - supports on-screen-display (OSD) and scaling functions
- embedded microcontrollers**
 - main ARM® Cortex® A5 MCU (CPU)
 - supports 32kB instruction cache and 32kB data cache
 - supports NEON® acceleration
 - secondary ARM® Cortex® A5 MCU (SPU: secondary processor unit)
 - supports 32kB instruction cache and 32kB data cache
 - supports NEON® acceleration
 - secondary 32-bit RISC MCU (MPU: media processor unit)
 - supports 8kB instruction cache and 8kB data cache
- DDR-SDRAM controller**
 - supports LPDDR2 16/32 bits wide
 - built-in DDR PHY which supports various external DDR memories
 - supports DDR3 and DDR3L 16/32 bits wide
- serial interfaces**
 - one serial flash master controller
 - five serial interface controller supporting master/slave mode
- general purpose I/O (GPIO)**
 - flexible GPIO capability for most of the I/O pins
 - 64 GPIOs equipped with interrupt capabilities
- miscellaneous**
 - dedicated JTAG interface
 - embedded PLLs
 - embedded USB PHY

Functional Block Diagram

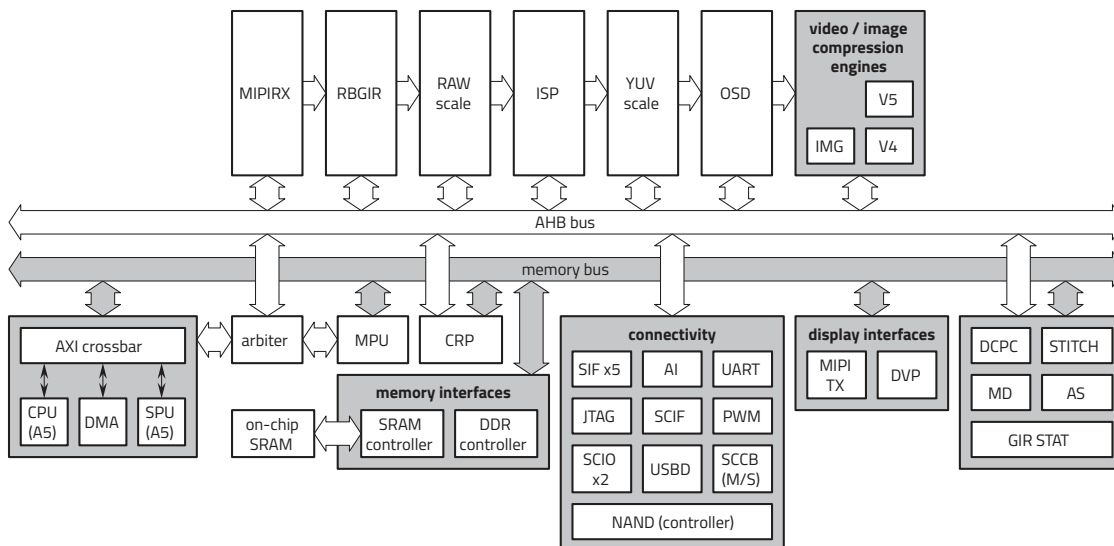

Version 1.1, June 2022