



# OX03F10

## 3 megapixel product brief



### Image Sensor Expands Family for Automotive Viewing Cameras with Higher 3MP Resolution and Added Cybersecurity

OMNIVISION's OX03F10 image sensor expands our next-generation ASIL-C viewing camera family with higher 3MP resolution and cybersecurity features that are required as vehicle designers make the transition from Level 2 and 3 advanced driver assistance systems (ADAS) to higher levels of autonomy. The OX03F10 also maintains the family's unique combination of a large 3.0 micron pixel size with a high dynamic range (HDR) of 140 dB and the best LED flicker mitigation (LFM) performance for minimized motion artifacts. Additionally, the sensor is offered in a 1/2.44" optical format and features a 4-lane MIPI CSI-2 interface.

The OX03F10 is integrated with our HALE (HDR and LFM engine) combination algorithm, which remains the only imaging technology that can simultaneously provide top HDR and LFM performance. Additionally, it can deliver the wide vertical array resolution of 1920 x 1536p at the highest rate of 60 frames per second (fps). This provides the high image quality needed when feeding surround view system (SVS) captures into autonomous, machine vision systems. The OX03F10's wider vertical array is also important in e-mirror applications, for wider coverage and blind-spot elimination.

The sensor maintains the industry's smallest package size, along with low power consumption, enabling the placement of cameras that continuously run at 60 fps in even the tightest spaces for

stringent styling requirements. It also retains the family's basic image processing capabilities, including defect pixel correction and lens correction. In combination with HALE, these features provide the greatest image quality for automotive viewing applications, across all lighting conditions and in the presence of flickering LEDs from headlights, road signs and traffic signals.

OMNIVISION's Deep Well™, dual conversion gain technology enables the OX03F10 to capture significantly lower motion artifacts than the few competing sensors that offer 140 dB HDR. Additionally, the company's split-pixel LFM technology with four captures offers the best performance over the entire automotive temperature range.

This next-generation family of viewing camera image sensors also features OMNIVISION's PureCel®Plus-S stacked architecture, which provides pixel performance advantages over nonstacked technology. For example, 3D stacking allowed OMNIVISION to boost pixel and dark current performance, resulting in a significant performance improvement over the prior generation of its viewing camera sensors.

Find out more at [www.ovt.com](http://www.ovt.com).



# OX03F10

## Ordering Information

- OX03F10-BB4Y-001B-Z (color, lead-free)  
84-pin a-BGA™ packed in tray without protective film

## Applications

- Automotive:
  - Surround View System
  - Rear View Camera
  - Autonomous Driving
  - E-Mirror

## Technical Specifications

- active array size:** 1920 x 1536
- temperature range:**
  - operating: -40°C to +105°C sensor ambient temperature and -40°C to +125°C junction temperature
- maximum image transfer rate:**
  - 1920 x 1536: 60 fps
- power supply:**
  - analog: 2.9V
  - digital: 1.1V
  - I/O pads: 1.8V
- power requirements:**
  - 430 mW (1920 x 1536 60 fps)
  - 390 mW (1920 x 1080 60 fps)
- output interfaces:**
  - up to 4-lane MIPI CSI-2
- lens size:** 1/2.44"
- lens chief ray angle:** 21.8°
- output formats:** uncompressed 24-bit, 20/16/14/12-bit (PWL) combined HDR (4 captures)
- pixel size:** 3 μm x 3 μm
- image area:** 5808 μm x 4656 μm

## Product Features

- support for image size:
  - 1920 x 1536, and any cropped size
- up to 4 captures and on-chip combination HDR output
- motion free HDR (3 capture)
- 4 capture HDR optimized to reduce motion artifacts
- LFM support (SPD)
- SCCB for register programming
- high speed serial data transfer with MIPI CSI-2
- safety features for supporting ASIL C applications
- image sensor processor functions:
  - lens shading correction
  - defective pixel cancellation
  - HDR combination
  - automatic black level correction
  - PWL compression, etc.
- cybersecurity for camera/host interface hacking preventing
- external frame synchronization capability
- embedded temperature sensor
- embedded supply voltage monitor
- one-time programmable (OTP) memory

## Functional Block Diagram

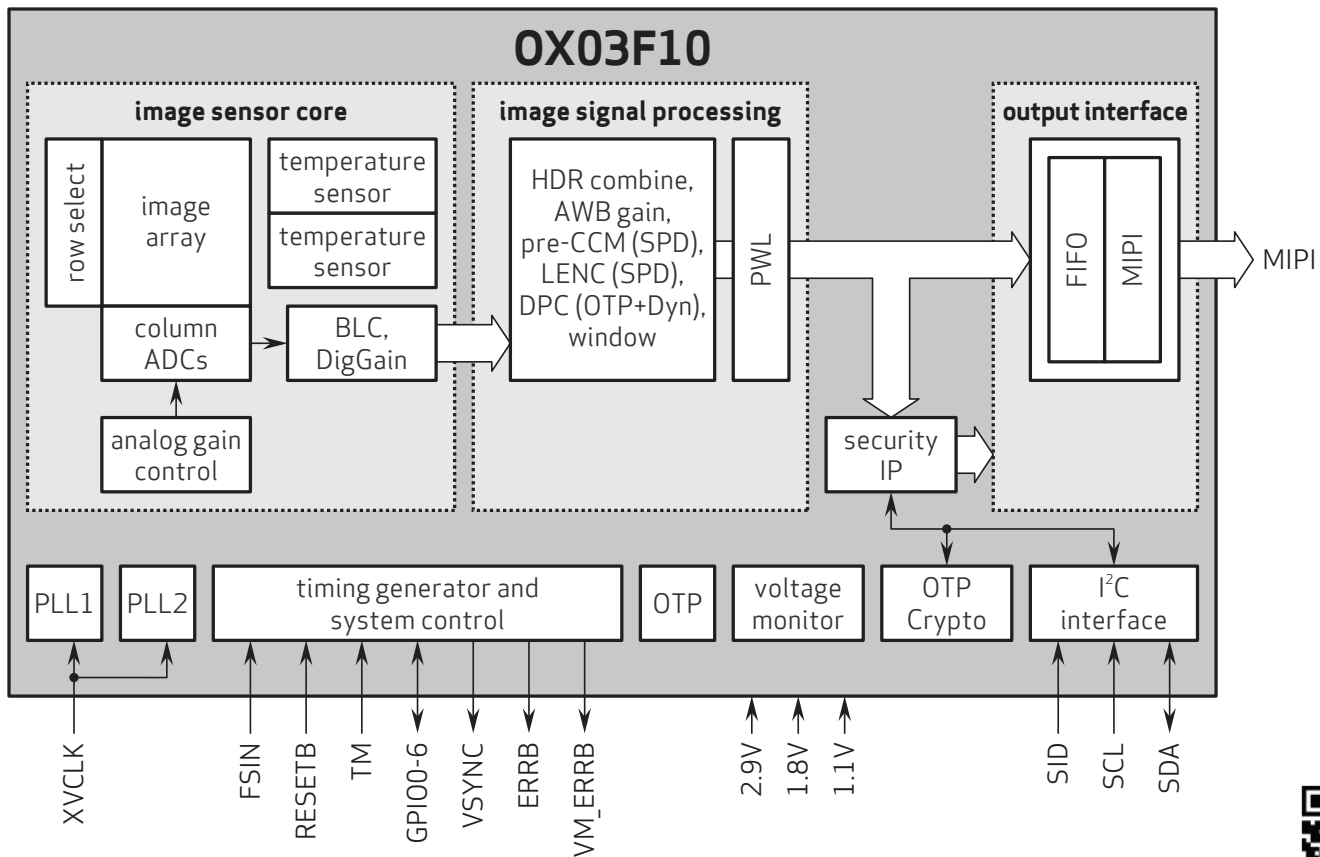

Version 1.1, May 2022

4275 Burton Drive  
Santa Clara, CA 95054  
USA

Tel: + 1 408 567 3000  
Fax: + 1 408 567 3001  
www.ovt.com

OMNIVISION reserves the right to make changes to their products or to discontinue any product or service without further notice. OMNIVISION and the OMNIVISION logo are trademarks or registered trademarks of OmniVision Technologies, Inc. PureCel is a registered trademark of OmniVision Technologies, Inc. Deep Well and a-BGA are trademarks of OmniVision Technologies, Inc. All other trademarks are the property of their respective owners.

OMNIVISION™