

## WL2863E

**Ultra-Low Noise, High PSRR LDO, 250mA Linear Regulator for RF and Analog Circuits**

### Descriptions

The WL2863E is a linear regulator capable of supplying 250-mA output current. Designed to meet the requirements of RF and analog circuits, the WL2863E device provides low noise, high PSRR, low quiescent current and very good load /line transients.

The device is designed to work with a 1 $\mu$ F input and 1 $\mu$ F output ceramic capacitor (no separate noise Operation bypass capacitor is required).

The WL2863E regulators are available in standard SOT-23-5L Package. Standard products are Pb-free and Halogen-free.

### Features

- Input Voltage Range :2.2V~5.5V
- Output Voltage Range :1.2V~4.3V
- Output current :250mA
- PSRR :Typ.100dB at 10mA, f =1KHz  
:Typ. 45dB at 10mA , f =1MHz
- Low Dropout :Typ. 115mV at 250mA
- Quiescent current :Typ. 21 $\mu$ A
- Low Output Voltage Noise:Typ. 7 $\mu$ VRMS
- Output Voltage Tolerance : $\pm$ 2%
- Shutdown Current :Typ. 0.01 $\mu$ A
- UVLO Threshold(V) :Typ. 1.90V
- Recommend capacitor :1uF
- Stable with 1 $\mu$ F Ceramic Input and Output capacitor
- No Noise Bypass Capacitor Required
- Thermal-Overload Protection

### Applications

- Cell phones , radiophone, digital cameras
- Bluetooth, wireless handsets
- HiFi products
- Others portable electronics device

<http://www.ovt.com>

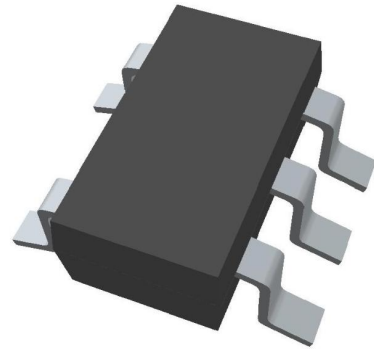

**SOT-23-5L**

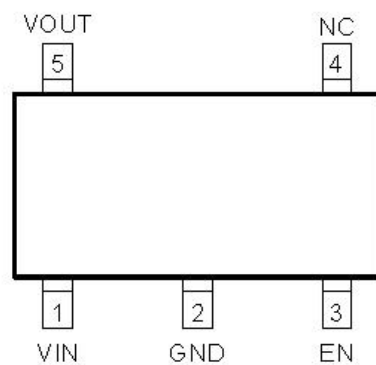

**Pin Configuration (Top View)**

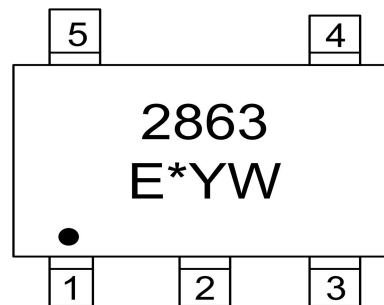

### Marking

**2863** : Device Code  
**E** : Special Code  
**\*** : Voltage Code  
**Y** : Year Code  
**W** : Week Code

### Order Information

For detail order information, please see page 11

Typical Application

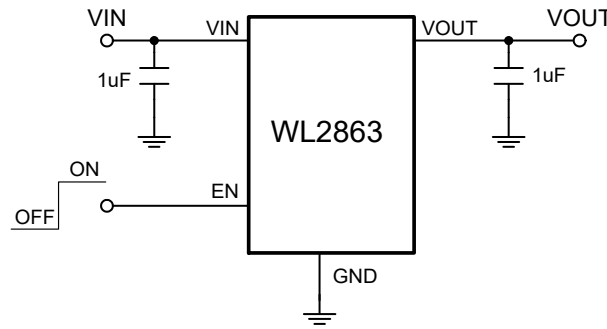

Note : The input and output capacitor must be located a distance of not more than 1 cm

PIN Functions

PIN	Symbol	Description
1	VIN	Input voltage supply pin , 1µF capacitor should be connected at this input
2	GND	Common ground connection
3	EN	Chip enable: Applying $V_{EN} < 0.4\text{ V}$ disables the regulator, Pulling $V_{EN} > 1.2\text{ V}$ enables the LDO.
4	NC	No internal electrical connection
5	VOUT	Regulated output voltage. 1µF capacitor should be connected at this input

Block Diagram

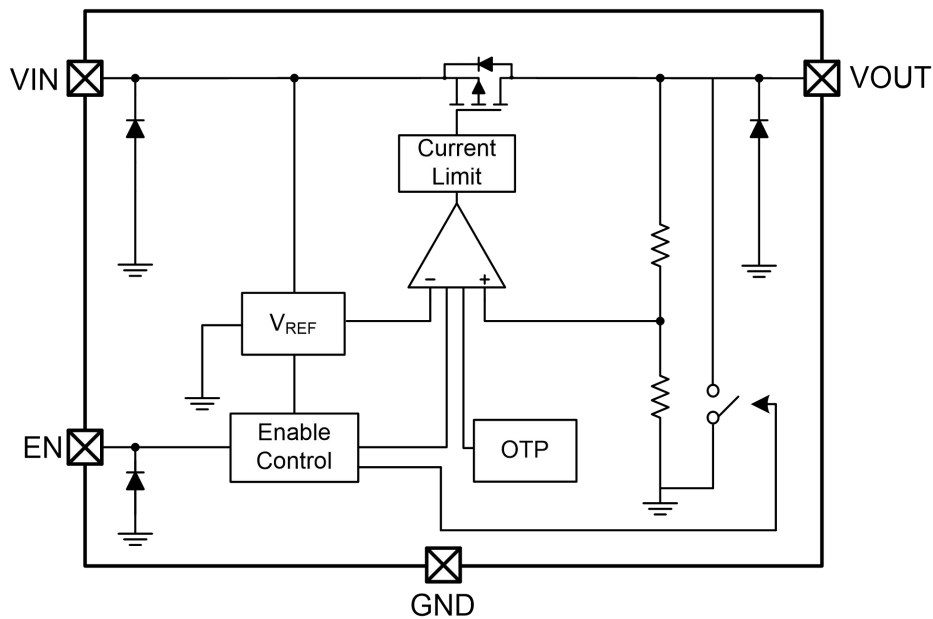

### Absolute Maximum Ratings

Parameter	Value	Unit	
Power Dissipation, $P_D@T_A=25^\circ\text{C}$	Internally Limited	mW	
$V_{IN}$ Range	-0.3~6.0	V	
$V_{EN}$ Range	-0.3 to $V_{IN} + 0.3$	V	
$V_{OUT}$ Range	-0.3 to $V_{IN} + 0.3$	V	
$I_{OUT}$	250	mA	
Lead Temperature Range	260	$^\circ\text{C}$	
Moisture Sensitivity Level	Level-3		
Storage Temperature Range	-55 ~ 150	$^\circ\text{C}$	
Operating Junction Temperature Range	150	$^\circ\text{C}$	
ESD Ratings	HBM	2000	V
	MM	200	V

### Recommend Operating Ratings

Parameter	Value	Unit
Operating Input Voltage Range <sup>(1)</sup>	2.2~5.5	V
Operating Output Voltage Range	1.2~4.3	V
Operating Temperature Range	-40~85	$^\circ\text{C}$
Thermal Resistance, $R_{\theta JA}$	250	$^\circ\text{C/W}$

(1) In order to achieve high performance of PSRR, it is recommended that the  $V_{IN}$  needs to be no smaller than ( $V_{OUT}+0.5\text{V}$ ).

**Electronics Characteristics ( $V_{IN}=V_{OUT(NOM)}+1V$ ,  $C_{IN}=C_{OUT}=1\mu F$ ,  $V_{EN} = 1.2 V$ . Typical values are at  $T_a = +25^\circ C$ , unless otherwise noted)**

Parameter	Symbol	Condition	Min.	Typ.	Max.	Unit
Operating Input Voltage	$V_{IN}$		2.2		5.5	V
Output Voltage Accuracy	$V_{OUT}$	$V_{IN} = V_{OUT(NOM)} + 1 V$ $I_{OUT}=1mA$	-2		+2	%
Output Current Limit	$I_{LIM}$	$V_{OUT} = 90\% V_{OUT(NOM)}$	250			mA
Dropout Voltage		$V_{OUT}=2.8V_{(NOM)}$ , $I_{OUT}=250mA$		115	170	mV
		$V_{OUT}=3.0V_{(NOM)}$ , $I_{OUT}=250mA$		108	162	
		$V_{OUT}=3.3V_{(NOM)}$ , $I_{OUT}=250mA$		102	150	
Line Regulation	$\Delta V_{LINE}$	$V_{IN}=2.2V\sim 5V$ , $I_{OUT}=1mA$		0.1		mV
Load Regulation	$\Delta V_{Load}$	$I_{OUT}=1\sim 200mA$		15		mV
Quiescent Current	$I_Q$	$I_{OUT}=0mA$		21	25	$\mu A$
Short Current	$I_{SHORT}$	$V_{OUT}=0V$		390		mA
Shut-down Current	$I_{SHDN}$	$V_{EN} = 0.4 V$ , $V_{IN} = 4.8 V$		0.01	1.0	$\mu A$
Power Supply Rejection Rate	PSRR	$I_{OUT} = 10mA$		f=100Hz	95	dB
				f=1KHz	100	
				f=100KHz	60	
				f=1MHz	45	
EN logic high voltage	$V_{ENH}$	$V_{IN}=5.5V$ , $I_{OUT}=1mA$	1.2			V
EN logic low voltage	$V_{ENL}$	$V_{IN}=5.5V$ , $V_{OUT}=0V$			0.4	V
EN Input Current	$I_{EN}$	$V_{EN} = 0$ to $5.5V$			1	$\mu A$
Turn-On Time		$C_{OUT} = 1\mu F$ , From assertion of $V_{EN}$ to $V_{OUT} = 95\% V_{OUT(NOM)}$		1.5		mS
Output Voltage Noise	$e_{NO}$	10Hz to 100KHz,	$I_{OUT} = 1mA$ $I_{OUT} = 200mA$	7 5		$\mu VRMS$
Thermal shutdown threshold	$T_{SDH}$	Temperature rising		150		$^\circ C$
	$T_{SDL}$	Temperature falling		120		$^\circ C$
Under voltage lock out threshold	$V_{UVLO}$			1.9		V
Active Output Discharge Resistance	$R_{LOW}$	$V_{EN}<0.4V$		300		$\Omega$
Line Transient	$Tran_{LINE}$	$V_{IN} = (V_{OUT(NOM)} + 2 V)$ to $(V_{OUT(NOM)} + 1 V)$ in 30 us, $I_{OUT} = 1 mA$	-1			mV
		$V_{IN} = (V_{OUT(NOM)} + 1 V)$ to $(V_{OUT(NOM)} + 2 V)$ in 30 us, $I_{OUT} = 1 mA$			+1	
Load Transient	$Tran_{LOAD}$	$I_{OUT} = 1 mA$ to $200 mA$ in 10 us	-10			mV
		$I_{OUT} = 200 mA$ to $1 mA$ in 10 us			+10	

Typical characteristics ( $T_a=25^\circ\text{C}$ ,  $V_{IN}=V_{OUT}+1\text{V}$ ,  $C_{IN}=C_{OUT}=1\mu\text{F}$ , unless otherwise noted)

$V_{OUT}=1.8\text{V}$

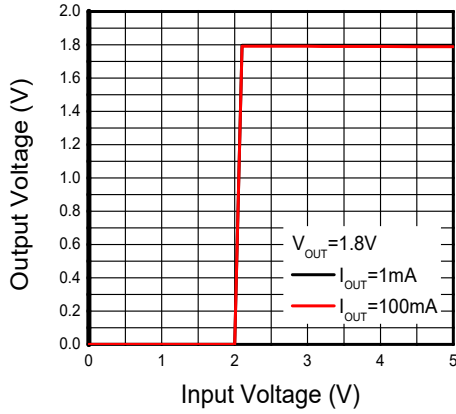

Output voltage vs. Supply voltage

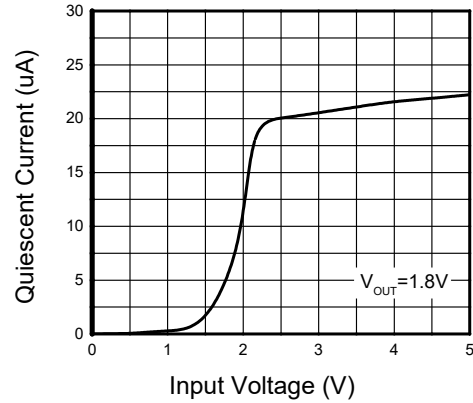

Quiescent current vs. Supply voltage

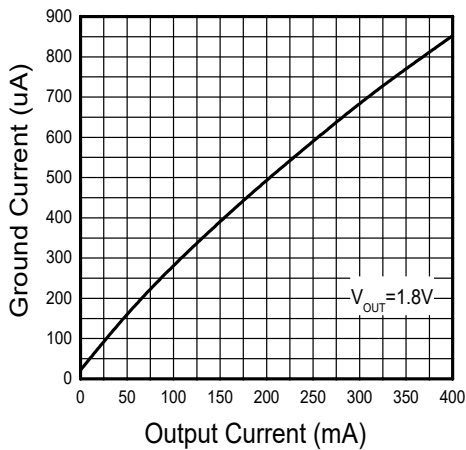

Ground Current vs. Output Current

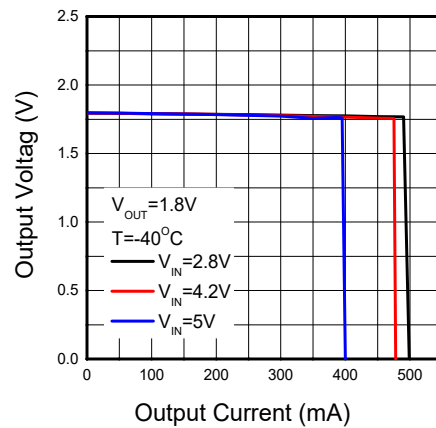

Output voltage vs. Output current

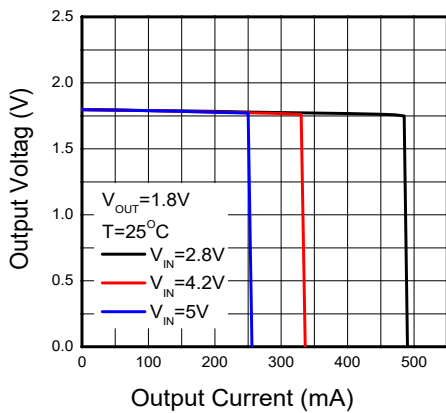

Output voltage vs. Output current

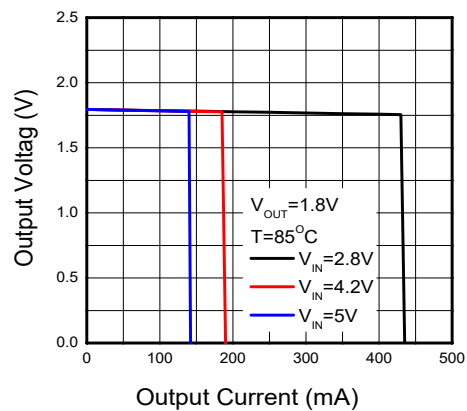

Output voltage vs. Output current

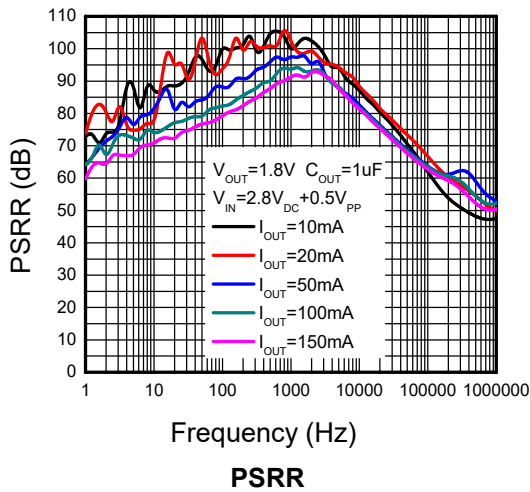

**$V_{OUT} = 2.8V$**

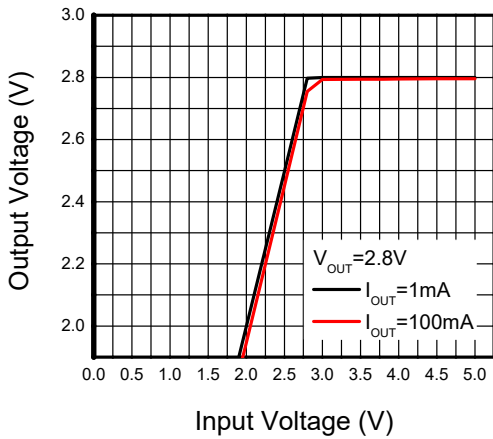

**Output voltage vs. Supply voltage**

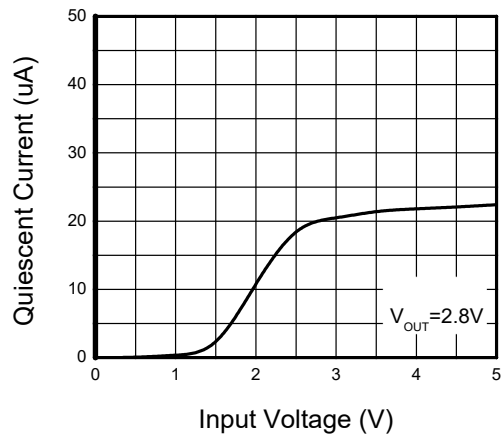

**Quiescent current vs. Supply voltage**

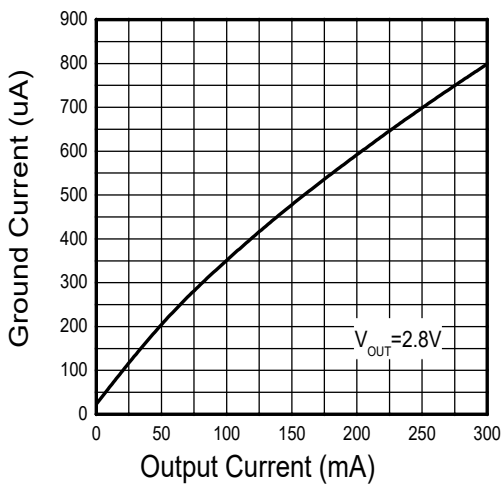

**Ground Current vs. Output Current**

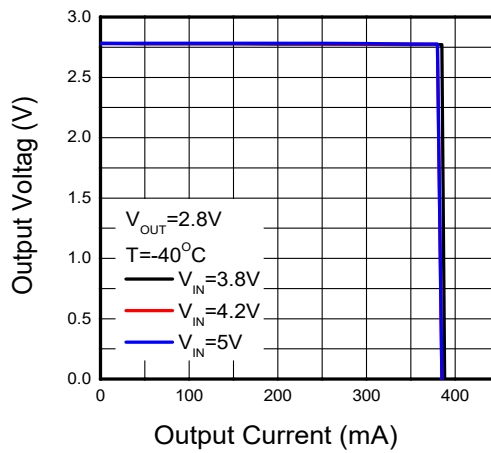

**Output voltage vs. Output current**

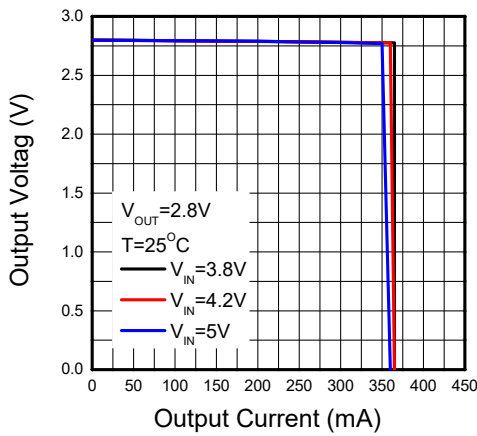

Output voltage vs. Output current

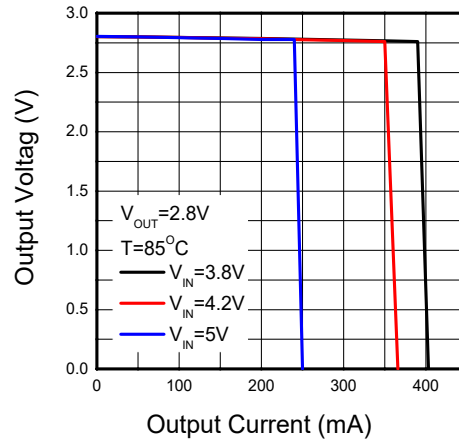

Output voltage vs. Output current

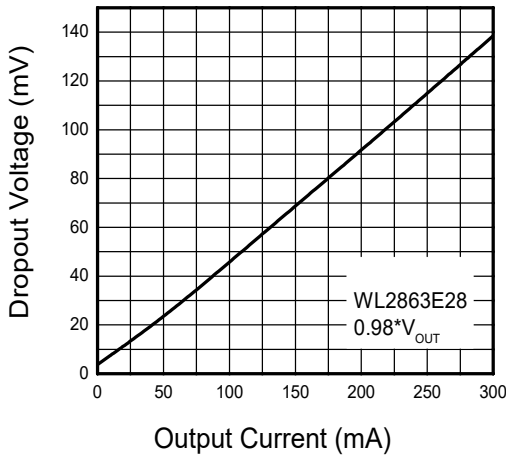

Dropout Voltage vs. Output Current

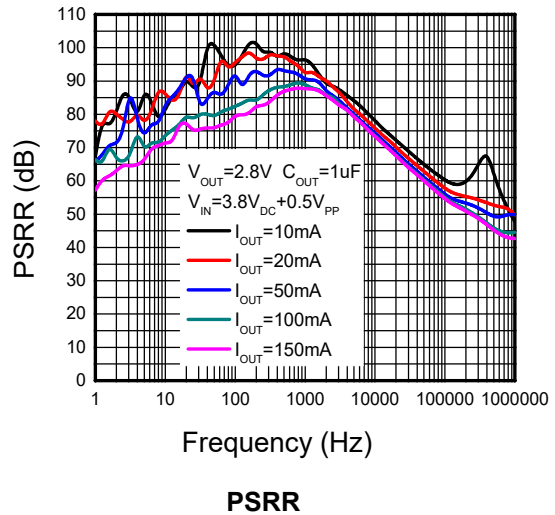

PSRR

**V<sub>OUT</sub>=3.3V**

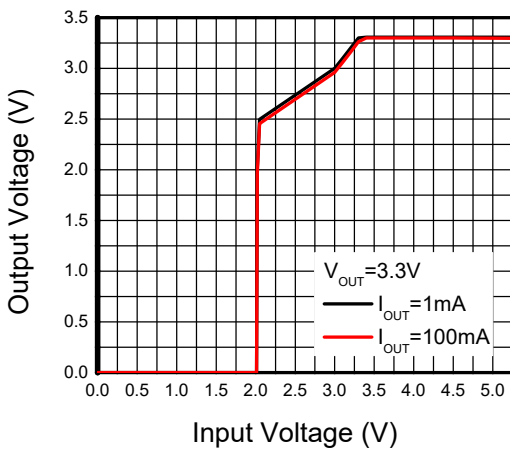

Output voltage vs. Supply voltage

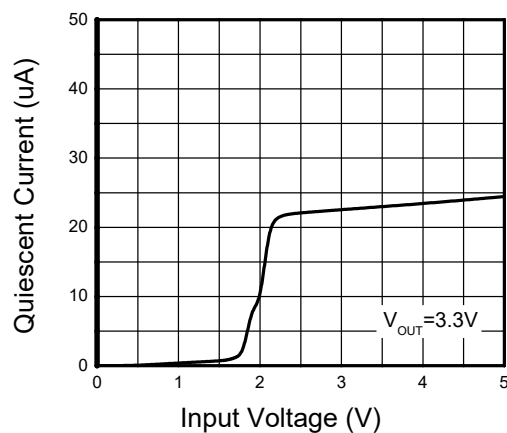

Quiescent current vs. Supply voltage

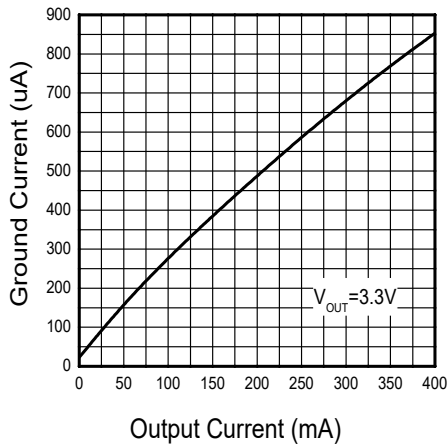

Ground Current vs. Output Current

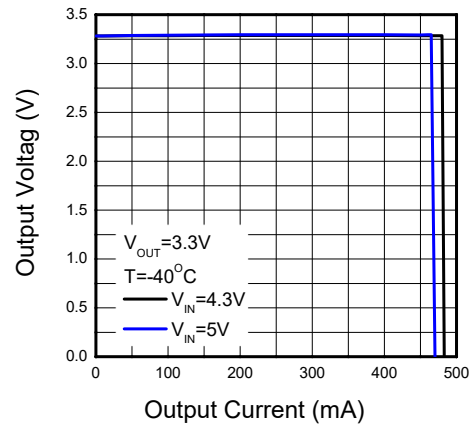

Output voltage vs. Output current

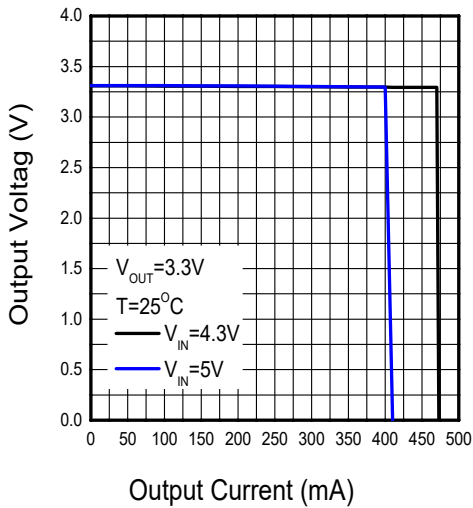

Output voltage vs. Output current

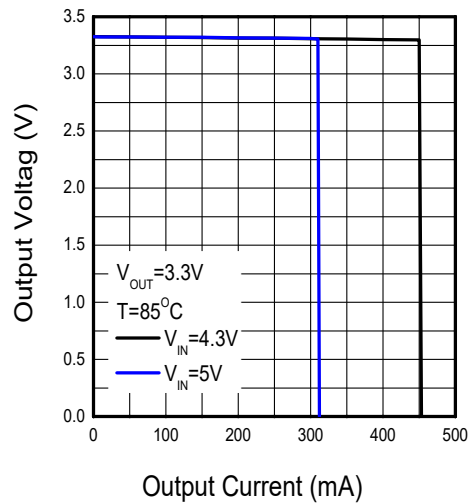

Output voltage vs. Output current

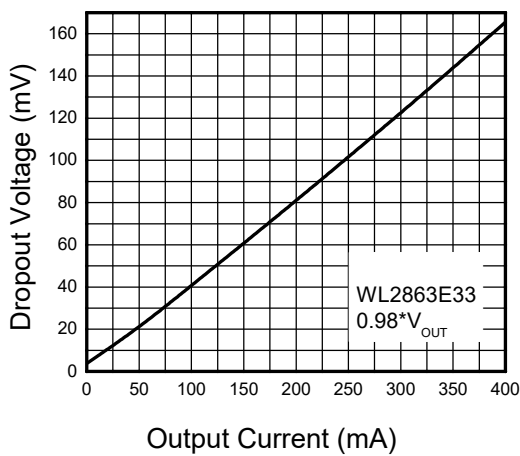

Dropout Voltage vs. Output Current

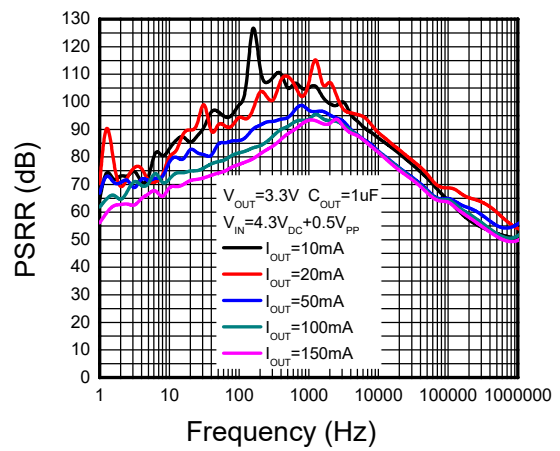

PSRR



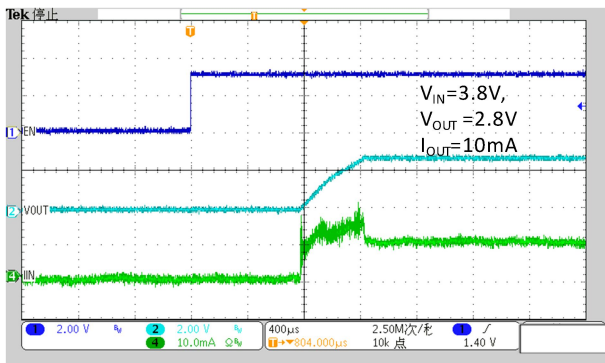

Soft-Start From EN

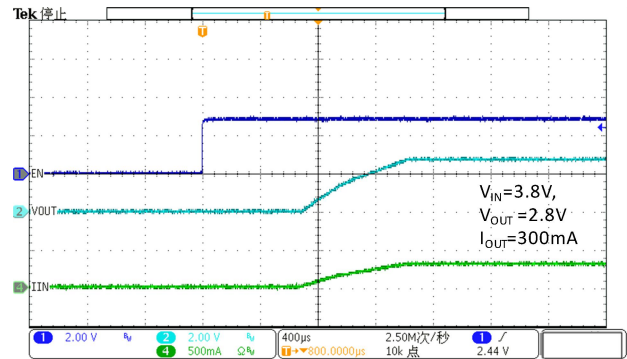

Soft-Start From EN

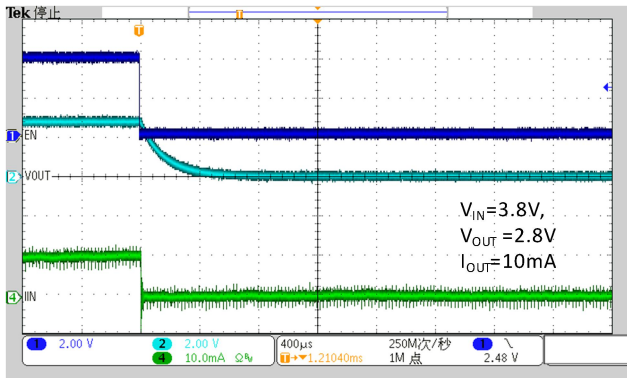

EN Shutdown

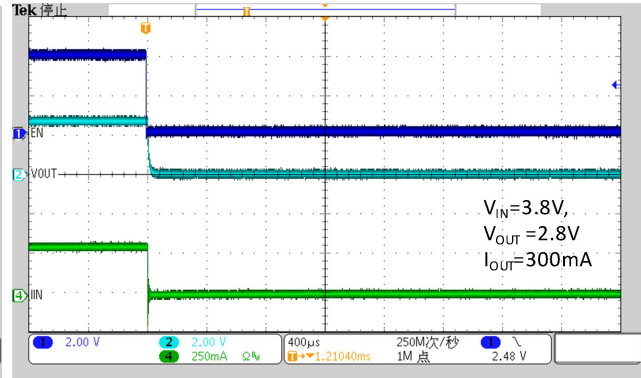

EN Shutdown

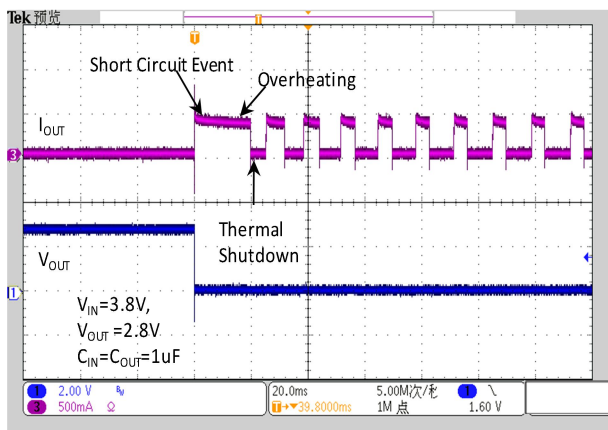

Short Circuit and Thermal Shutdown

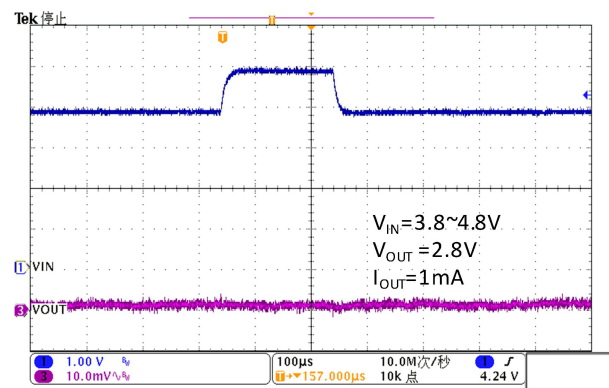

Line Transient Response

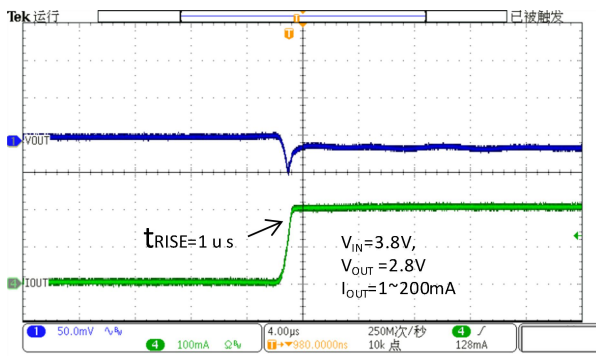

Load Transient Response

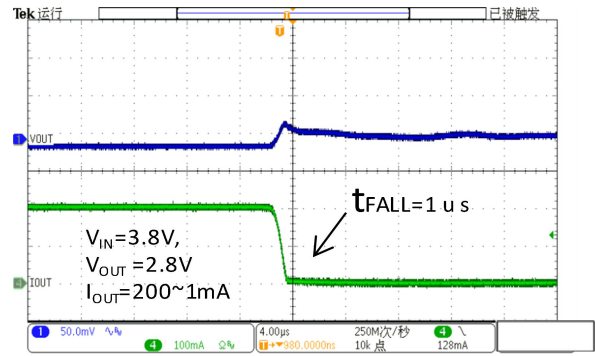

Load Transient Response

## ORDER INFORMATION

Ordering No.	Vout (V)	Package	Operating Temperature	Marking	Shipping
WL2863E12-5/TR	1.2	SOT-23-5L	-40~+85°C	2863 EEYW	Tape and Reel, 3000
WL2863E15-5/TR	1.5	SOT-23-5L	-40~+85°C	2863 EGYW	Tape and Reel, 3000
WL2863E18-5/TR	1.8	SOT-23-5L	-40~+85°C	2863 EHYW	Tape and Reel, 3000
WL2863E25-5/TR	2.5	SOT-23-5L	-40~+85°C	2863 EKYW	Tape and Reel, 3000
WL2863E28-5/TR	2.8	SOT-23-5L	-40~+85°C	2863 ELYW	Tape and Reel, 3000
WL2863E29-5/TR	2.9	SOT-23-5L	-40~+85°C	2863 EgYW	Tape and Reel, 3000
WL2863E30-5/TR	3.0	SOT-23-5L	-40~+85°C	2863 EMYW	Tape and Reel, 3000
WL2863E33-5/TR	3.3	SOT-23-5L	-40~+85°C	2863 ENYW	Tape and Reel, 3000

### Marking

**2863** : Device Code

**E** : Special Code

**\*** : Voltage Code

**Y** : Year Code

**W** : Week Code

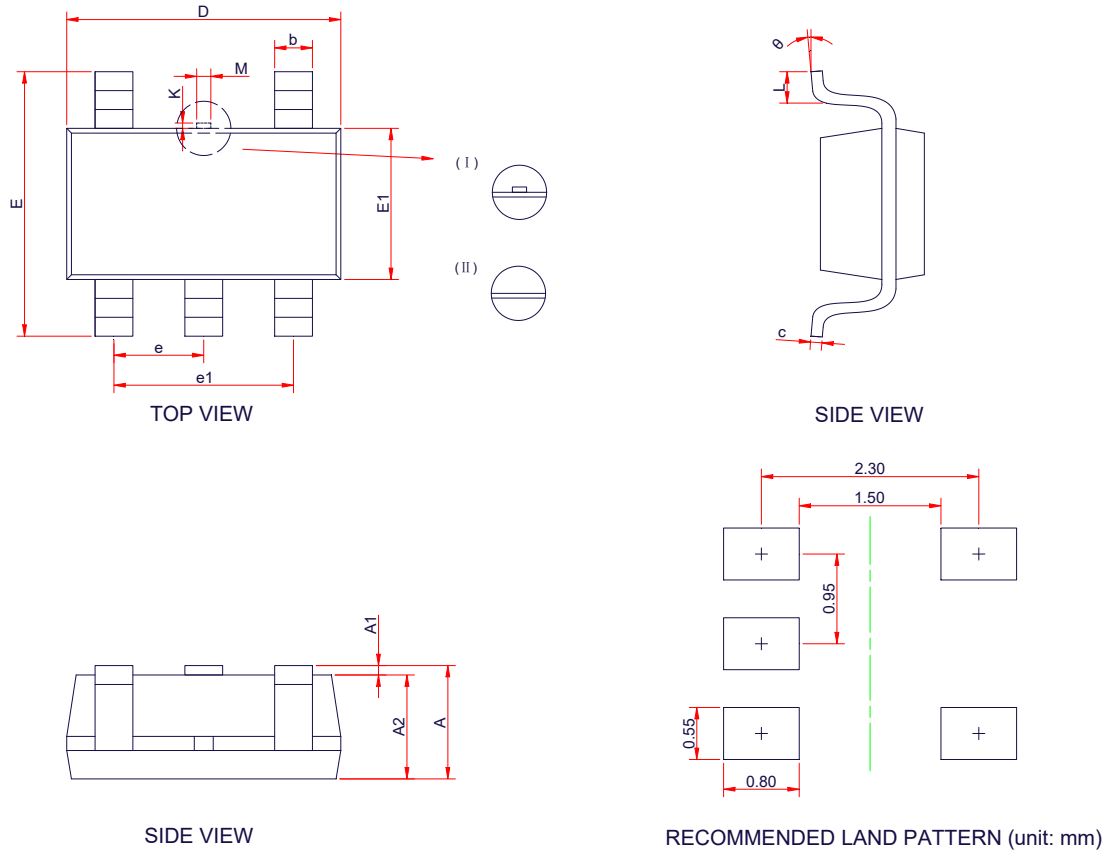
**PACKAGE OUTLINE DIMENSIONS**
**SOT-23-5L**

Symbol	Dimensions in Millimeters		
	Min.	Typ.	Max.
A	-	-	1.25
A1	0.00	-	0.15
A2	1.00	1.10	1.20
b	0.30	0.40	0.50
c	0.10	-	0.21
D	2.72	2.92	3.12
E	2.60	2.80	3.00
E1	1.40	1.60	1.80
e	0.95 BSC		
e1	1.90 BSC		
L	0.30	0.45	0.60
M	0.10	0.15	0.25
K	0.00	-	0.25
$\theta$	0°	-	8°

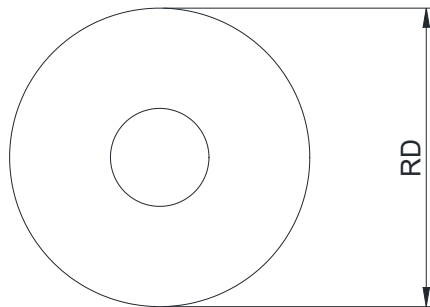
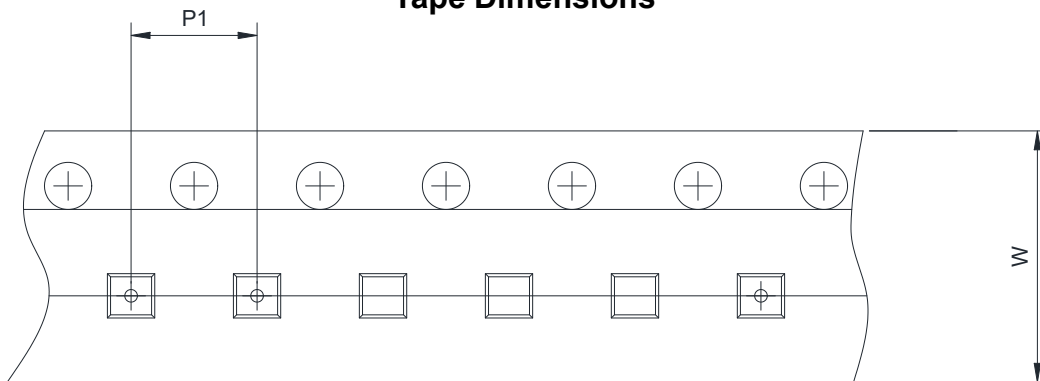
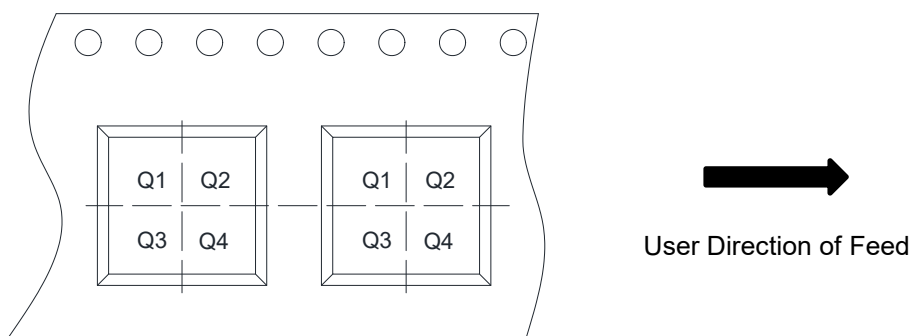
**TAPE AND REEL INFORMATION**
**Reel Dimensions**

**Tape Dimensions**

**Quadrant Assignments For PIN1 Orientation In Tape**

RD	Reel Dimension	<input checked="" type="checkbox"/> 7inch	<input type="checkbox"/> 13inch
W	Overall width of the carrier tape	<input checked="" type="checkbox"/> 8mm	<input type="checkbox"/> 12mm <input type="checkbox"/> 16mm
P1	Pitch between successive cavity centers	<input type="checkbox"/> 2mm	<input checked="" type="checkbox"/> 4mm <input type="checkbox"/> 8mm
Pin1	Pin1 Quadrant	<input type="checkbox"/> Q1	<input type="checkbox"/> Q2 <input checked="" type="checkbox"/> Q3 <input type="checkbox"/> Q4