

OX01E10 1.3MP product brief



Automotive SoC for Entry-Level Rearview Cameras with Industry's Best Low-Light Performance, Lowest Power and Smallest Size



available in a lead-free package

OmniVision's OX01E10 is a 1.3 megapixel (MP) SoC in a 1/4" optical format, providing the automotive industry's best imaging performance for entry-level rearview cameras (RVC) across a wide range of challenging lighting conditions, along with the most compact form factor and lowest power consumption. It integrates a 3 micron image sensor and an advanced image signal processor (ISP), enabling designers to achieve a small form factor with excellent low-light performance, ultra-low power and reduced cost while improving reliability by using only one printed circuit board (PCB).

The OX01E10's sensor is built on the PureCel[®]Plus pixel architecture, renowned for its low-light sensitivity and providing the industry's best SNR performance. Additionally, it provides two on-screen display overlay layers for driver guidelines, as well as distortion correction to straighten any curved edges from lenses with a wide viewing angle.

This is the only imaging device for entry-level RVC that doesn't require a metal heat sink, allowing plastic camera module bodies to reduce costs. With its compact package size, it enables smaller

cameras that can fit in tighter spaces. Additionally, by integrating both the sensor and ISP into a single chip, designers can save on both cost and space by eliminating the second PCB in typical two-chip implementations.

OmniVision's dual conversion gain technology is employed in this SoC to achieve an HDR of 120 dB with only two captures. Its integrated ISP further enables superior image quality with a number of advanced features, such as lens chromatic aberration correction, and advanced noise reduction and local tone mapping.

The OX01E10 SoC provides a 1340 x 1020 array size at 30 fps. It also enables output flexibility with both 2-lane MIPI and 10-bit DVP interfaces, and is AEC-Q100 Grade 2 certified.

Find out more at www.ovt.com.



OmniVision

Applications

- 360° Surround View System
- Rear View Camera

OX01E10



Product Features

- support for image size:
 - 1340 x 1020, and any cropped size
- high dynamic range
- high sensitivity
- dual conversion gain
- ASIL-B safety feature
- image sensor process functions:
 - AEC/AGC/AWB
 - lens correction
 - defective pixel correction
 - HDR combination
 - tone mapping
 - automatic black level correction
- supported output formats:
 - YUV
 - RGB888
 - BT656
 - RAW
- SPI master for overlay and loading settings
- distortion correction
- 50/60 Hz flicker cancellation
- SCCB for register programming
- programmable GPIOs
- high speed serial data transfer with MIPI CSI-2 or DVP
- external frame synchronization capability
- embedded temperature sensor
- one-time programmable (OTP) memory

Ordering Information

- OX01E10-B58Y-1C-Z (color, lead-free) 58-pin a-BGA™, rev 1C, packed in tray without protective film
- OX01E10-E48Y-1D-Z (color, lead-free) 48-pin a-CSP™, rev 1D, packed in tray without protective film

Product Specifications

- active array size: 1340 x 1020
- lens size: 1/3.55" for 1340 x 1020 image size
- lens chief ray angle: 20° linear
- scan mode: progressive
- shutter: rolling shutter
- output formats: linear output, dual exposure HDR (long and short), 3-exposure HDR (long, short, and very short)
- maximum image transfer rate: 30 fps @ 1340 x 1020 in 10-bit
- dynamic range: 120 dB in 3-capture HDR
- pixel size: 3 μm x 3 μm
- image area: 4080 μm x 3108 μm
- package cover glass type: double sided anti-reflective (AR/AR) coating without IRCF
- power supply:
 - analog: 3.3V
 - digital: 1.1V
 - I/O pins: 1.8V or 3.3V
- power requirements:
 - active:
 - 335 mW/315 mW (streaming 1340 x 1020 @ 30 fps YUV DVP/MIPI typical)
 - 315 mW/300 mW (streaming 1280 x 960 @ 30 fps YUV DVP/MIPI typical)
 - 270 mW/260 mW (streaming 1280 x 720 @ 30 fps YUV DVP/MIPI typical)
- temperature range:
 - operating: -40°C to +105°C sensor ambient temperature and -40°C to +125°C junction temperature
- output interfaces: up to 2-lane MIPI CSI-2 and 96 MHz parallel clock

Functional Block Diagram

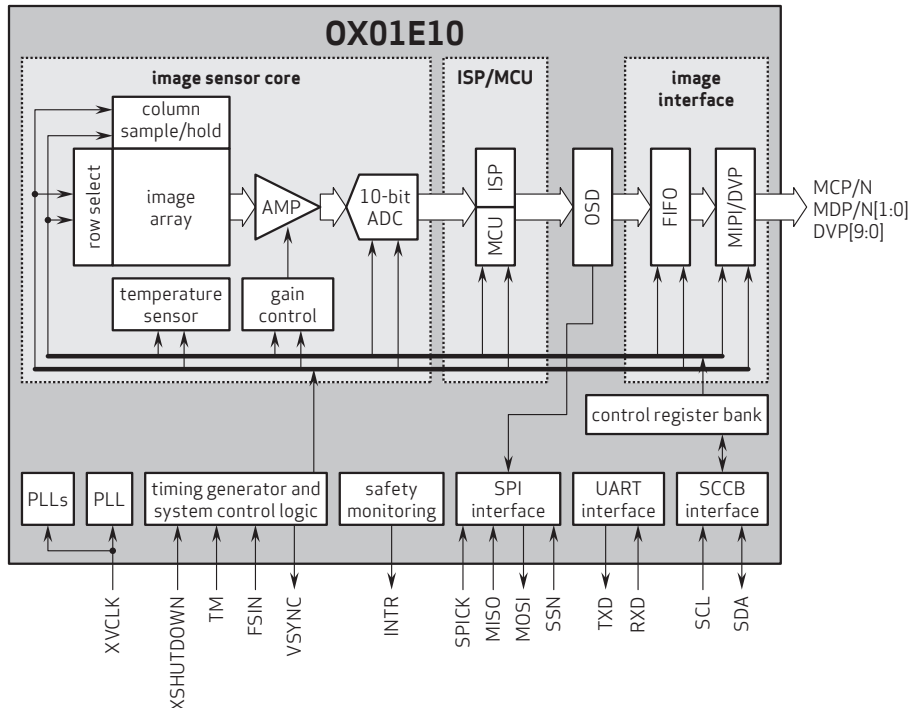

4275 Burton Drive
Santa Clara, CA 95054
USA

Tel: +1 408 567 3000
Fax: +1 408 567 3001
www.ovt.com

OmniVision reserves the right to make changes to their products or to discontinue any product or service without further notice. OmniVision and the OmniVision logo are registered trademarks of OmniVision Technologies, Inc. a-BGA and a-CSP are trademarks of OmniVision Technologies, Inc. All other trademarks used herein are the property of their respective owners.



OmniVision