

# OX01D10 1.2MP product brief



## Industry-leading 1MP Image Sensor for Automotive LED Flicker Mitigation with Smallest Split-Pixel Design



available in  
a lead-free  
package

OmniVision's OX01D10 is the next-generation 1MP image sensor for automotive viewing applications. The low-power consumption sensor enables rear-view and surround-view cameras with excellent image quality and more scene details via best-in-class resolution and high dynamic range of 110 dB in LFM mode. The image sensor brings together split pixel and dual conversion gain (DCG) technology, delivering motion free high dynamic range HDR to 120 dB and LED flicker mitigation (LFM). These features increase driver safety because more scene details can be captured by rear-view and surround-view cameras while operating over the full automotive temperature range, delivering excellent image quality in demanding lighting conditions, objects in motion, and LED signs/headlights.

The OX01D10 enables the industry's smallest and most power-efficient viewing camera modules by consuming less than 200 mW at the full 30 fps and providing the highest resolution in a 1/4-inch optical format. Additionally, the sensor has an advanced set of safety mechanisms to enable advanced ASIL features and HDR of 120 dB without LFM. It is AEC-Q100 Grade 2 certified for automotive applications and samples and evaluation kits are available now.

Find out more at [www.ovt.com](http://www.ovt.com).



## Applications

- 360° Surround View System
- E-Mirror
- Rear View Camera

## Product Features

- support for image size:
  - 1280 x 960, and any cropped size
- increased pixel array resolution for mechanical alignment support: +40 (H), +60 (V)
- HDR readout modes, with 3x captures: DCG (LPD) + SPD, on-chip HDR combination with LFM support LCG (LPD) + SPD + VS, off-chip HDR combination
- LED flicker mitigation (LFM)
- HDR optimized to reduce motion artifacts
- SCCB for register programming
- high speed serial data transfer with MIPI CSI-2
- image sensor processor functions:
  - lens shading correction
  - defective pixel cancellation
  - HDR combination
  - automatic black level correction
  - PWL compression, etc.
- ASIL-B safety feature
- parallel 12-bit DVP output
- external frame synchronization capability
- embedded temperature sensor
- embedded supply voltage monitor
- one-time programmable (OTP) memory

# OX01D10

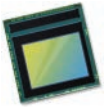

## Ordering Information

- **OX01D10-E63Y-1D** (color, lead-free)  
63-pin a-CSP™, rev 1D, packed in tray without protective film

## Technical Specifications

- **active array size:** 1336 x 1036
- **maximum image transfer rate:** 30 fps
- **power supply:**
  - analog: 3.3V
  - digital: 1.2V
  - I/O pads: 1.8V/3.3V
- **power requirements:**
  - active: streaming @ 960p30: 180 mW (measured with FuSa/ASIL off)
- **temperature range:**
  - operating: -40°C to +105°C sensor ambient temperature and -40°C to +125°C junction temperature
- **output interfaces:** up to 2-lane MIPI CSI-2, 12-bit DVP
- **lens size:** 1/4"
- **lens chief ray angle:** 20°
- **output formats:** 3x10b RAW: split pixel with captures (LCG, SPD, VS); DCG with split pixel (HCG, LCG, SPD), 12-bit compressed DCG RAW, 12-bit compressed HDR3 RAW (DCG, SPD)
- **pixel size:** 2.8 μm x 2.8 μm
- **image area:** 3740.8 μm x 2900.8 μm

## Functional Block Diagram

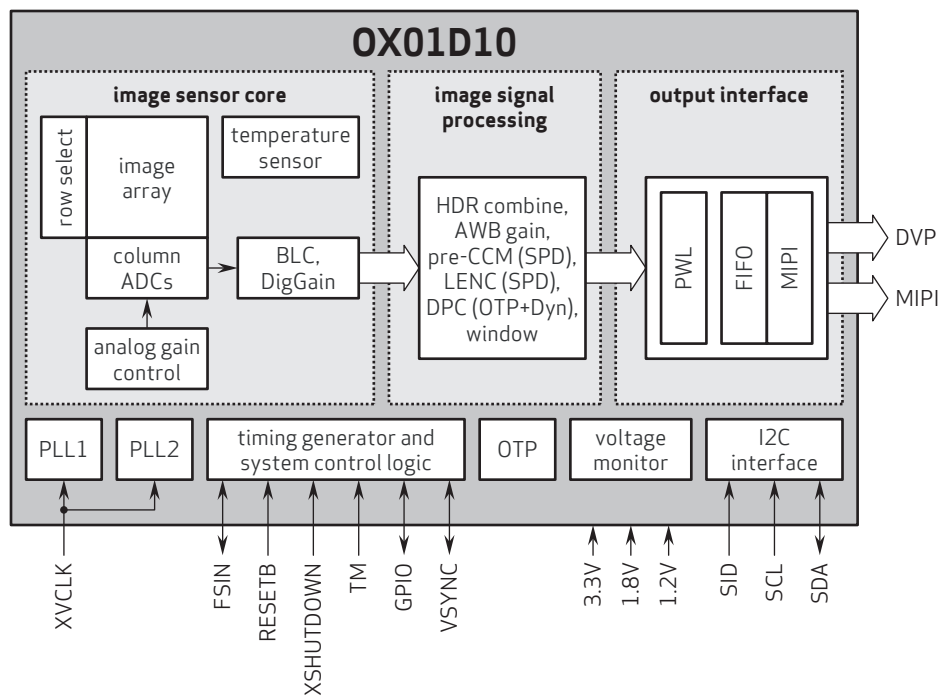

4275 Burton Drive  
Santa Clara, CA 95054  
USA

Tel: + 1 408 567 3000  
Fax: + 1 408 567 3001  
www.ovt.com

OmniVision reserves the right to make changes to their products or to discontinue any product or service without further notice. OmniVision and the OmniVision logo are registered trademarks of OmniVision Technologies, Inc. a-CSP is a trademark of OmniVision Technologies, Inc. All other trademarks used herein are the property of their respective owners.



**OmniVision**