



OV64C 64-megapixel product brief



64 Megapixel Image Sensor Offers Premium Resolution and Features for High End Smartphones



available in
a lead-free
package

OmniVision's OV64C is a high-performance 64 megapixel (MP) image sensor featuring a 0.8 micron pixel size to enable high resolution smartphone cameras in a 1/1.7" optical format. Built on OmniVision's PureCel[®]Plus stacked die technology, this sensor provides leading edge still image capture and exceptional 4K video performance with electronic image stabilization (EIS) for high end smartphones. The OV64C also delivers a wide range of features, such as 4-cell remosaic for full resolution Bayer output as well as digital crop zoom, and a CPHY interface for greater throughput using fewer pins, making it ideal for the main rear-facing camera in multicamera configurations.

This image sensor integrates an on-chip 4-cell color filter array and hardware re-mosaic, which provides high quality, 64MP Bayer output in real time. In low light conditions, the sensor can use near-pixel binning to output a 16MP image

with 4x the sensitivity, offering 1.6 micron equivalent performance for previews and still captures. In either case, the OV64C can consistently capture the best quality images, as well as enabling 2x digital crop zoom with 16MP resolution and fast mode switch.

The OV64C offers type-2, 2x2 microlens phase detection autofocus (ML-PDAF) to boost autofocus accuracy, especially in low light. The sensor provides options for multiple resolutions and frame-rate configurations, including 64MP at 15 frames per second (fps), 8K video at 30 fps, 16MP captures with 4-cell binning at 30 fps, 4K video at 60 fps and 4K video with EIS at 30 fps. Additionally, the OV64C supports 3-exposure, staggered HDR timing for up to 16MP video modes.

Find out more at www.ovt.com.



OmniVision.

Applications

- Smart Phones
- Video Conferencing
- PC Multimedia

Product Features

- suitable for module size of 11.80 x 11.30 x 6.65 mm
- automatic black level calibration (ABLC)
- programmable controls for:
 - frame rate
 - mirror and flip
 - binning
 - cropping
 - windowing
- support for dynamic DPC
- supports output formats: 10-bit RGB
- supports horizontal and vertical subsampling
- supports typical images sizes:
 - 9248 x 6944
 - 7680 x 4320
 - 4624 x 3472
 - 4608 x 2592
 - 3840 x 2160
 - 1920 x 1080
 - 1280 x 720
- standard serial SCCB interface
- up to 4-lane MIPI TX interface with speed up to 3 Gbps/lane
- 2/3 trio CPHY interface, up to 2.25 Gbps/trio
- supports type 2x2 ML PDAF
- 4-cell support:
 - 4-cell binning
 - 4-cell full
- HDR support: stagger HDR 2/3 exposure timing
- on-chip 4-cell to Bayer converter
- three on-chip phase lock loops (PLLs)
- programmable I/O drive capability
- built-in temperature sensor
- on chip digital scalar

OV64C



Ordering Information

- OV64C40-GA5A-002A**
(color, chip probing, 150 μm backgrinding, reconstructed wafer with good die)

Technical Specifications

- active array size:** 9248 x 6944
- maximum image transfer rate:**
 - 9248 x 6944: 15 fps
- power supply:**
 - core: 1.1V
 - analog: 2.8V
 - I/O: 1.8V
- power requirements:**
 - active: 790 mW (64MP @ 16 fps)
 - standby: <12 μA
- temperature range:**
 - operating: -30°C to +85°C junction temperature
 - stable: 0°C to +60°C junction temperature
- output formats:** 10-bit RGB RAW
- lens size:** 1/1.7"
- lens chief ray angle:** 34.9° non-linear
- pixel size:** 0.801 μm x 0.801 μm
- image area:** 7433.28 μm x 5587.776 μm

Functional Block Diagram

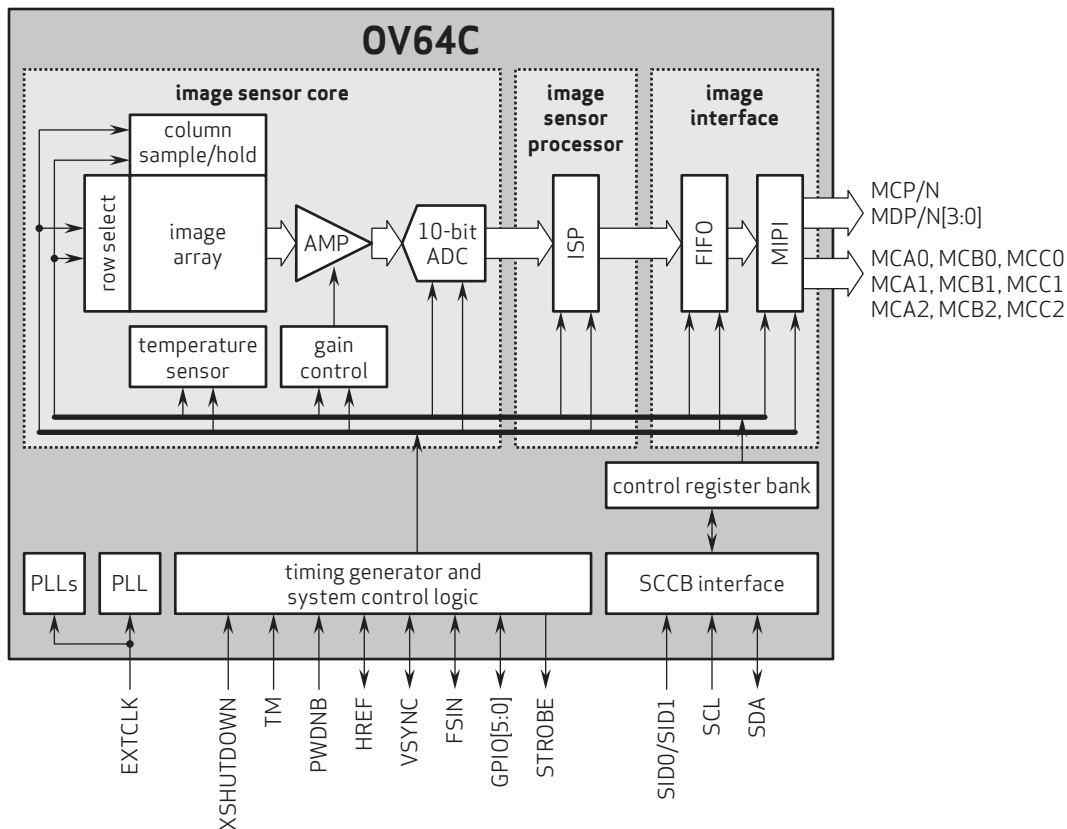

4275 Burton Drive
Santa Clara, CA 95054
USA

Tel: +1 408 567 3000
Fax: +1 408 567 3001
www.ovt.com

OmniVision reserves the right to make changes to their products or to discontinue any product or service without further notice. OmniVision, the OmniVision logo and PureCel are registered trademarks of OmniVision Technologies, Inc. All other trademarks are the property of their respective owners.



OmniVision