



OV48C 48-megapixel product brief



48MP Image Sensor Provides Unparalleled High Dynamic Range and 4K Video Performance for Flagship Mobile Phones



available in
a lead-free
package

OmniVision's OV48C is a 48 megapixel (MP) image sensor with a large 1.2 micron pixel size to enable high resolution and excellent low light performance for flagship smartphone cameras. The OV48C is the industry's first image sensor for high resolution mobile cameras with on-chip dual conversion gain HDR, which eliminates motion artifacts and produces an excellent signal-to-noise ratio (SNR). This sensor also offers a staggered HDR option with on-chip combination, providing smartphone designers with the maximum flexibility to select the best HDR method for a given scene. The OV48C is the only flagship mobile image sensor in the industry to offer the combination of high 48MP resolution, a large 1.2 micron pixel, high speed, and on-chip high dynamic range, which provides superior SNR, unparalleled low light performance and high quality 4K video.

Built on OmniVision's PureCel®Plus stacked die technology, this 1/1.3" optical format sensor provides leading-edge still image capture and video performance for flagship smartphones. The OV48C also integrates an on-chip, 4-cell color filter array and hardware remosaic, which provides high quality, 48MP Bayer output, or 8K video, in real time. In low light conditions, this

sensor can use near-pixel binning to output a 12MP image for 4K2K video with four times the sensitivity, yielding a 2.4 micron-equivalent performance. In either case, the OV48C can consistently capture the best quality images without motion blur, as well as enabling digital crop zoom with 12MP resolution and fast mode switch. Additionally, this sensor offers a wide range of features, including digital crop zoom and a CPHY interface, making it ideal for main, rear-facing cameras in multicamera configurations. The OV48C also uses 4C Half Shield phase detection for fast autofocus support.

The OV48C's output formats include 48MP at 15 frames per second (fps), 12MP with 4-cell binning at 60 fps, and 4K2K video at 60 fps with the extra pixels needed for electronic image stabilization. This sensor also offers 1080p video with slow motion support at 240 fps, as well as 720p at 360 fps.

Find out more at www.ovt.com.



OmniVision

Applications

- Smart Phones
- PC Multimedia
- Video Conferencing

Product Features

- automatic black level calibration (ABLC)
- programmable controls for:
 - frame rate
 - mirror and flip
 - binning
 - cropping
 - windowing
- support for dynamic DPC
- supports output formats:
 - 10-bit RGB 4C non HDR
 - 10-bit RGB Bayer non HDR
 - up to 14-bit Bayer HDR
- supports horizontal and vertical subsampling
- supports typical images sizes:
 - 8064 x 6048
 - 4032 x 3023
 - 3840 x 2160
 - 1920 x 1080
 - 1280 x 720
- standard serial SCCB interface
- up to 4-lane MIPI TX interface with speed up to 2.6 Gbps/lane
- 2/3 trio CPHY interface, up to 2.1 Gbps/trio
- supports Type 2 4C HS PDAF
- 4-cell support:
 - 4-cell binning
 - 4-cell full
- HDR support:
 - DCG output with on-chip combination
 - stagger HDR 2 exposure with on-chip combination
 - stagger HDR 2/3 exposure timing
- on-chip 4-cell to Bayer converter
- three on-chip phase lock loops (PLLs)
- programmable I/O drive capability
- built-in temperature sensor
- 1.197 μm DCG pixel

OV48C



Ordering Information

- OV48C40-GA5A-002A**
(color, chip probing, 150 μm backgrinding, reconstructed wafer with good die)

Technical Specifications

- active array size:** 8064 x 6048
- maximum image transfer rate:**
 - 8064 x 6048: 15 fps
- power supply:**
 - core: 1.1V
 - analog: 2.8V
 - I/O: 1.8V
- power requirements:**
 - active: 558 mW (48MP @ 15 fps)
 - standby: 2 μA
- temperature range:**
 - operating: -30°C to +85°C junction temperature
 - stable: 0°C to +60°C junction temperature
- output formats:** 10/12/14-bit for HDR RGB RAW
- lens size:** 1/1.32"
- lens chief ray angle:** 36.1° non-linear
- scan mode:** progressive
- pixel size:** 1.197 μm x 1.197 μm
- image area:** 9690.912 μm x 7277.76 μm

Functional Block Diagram

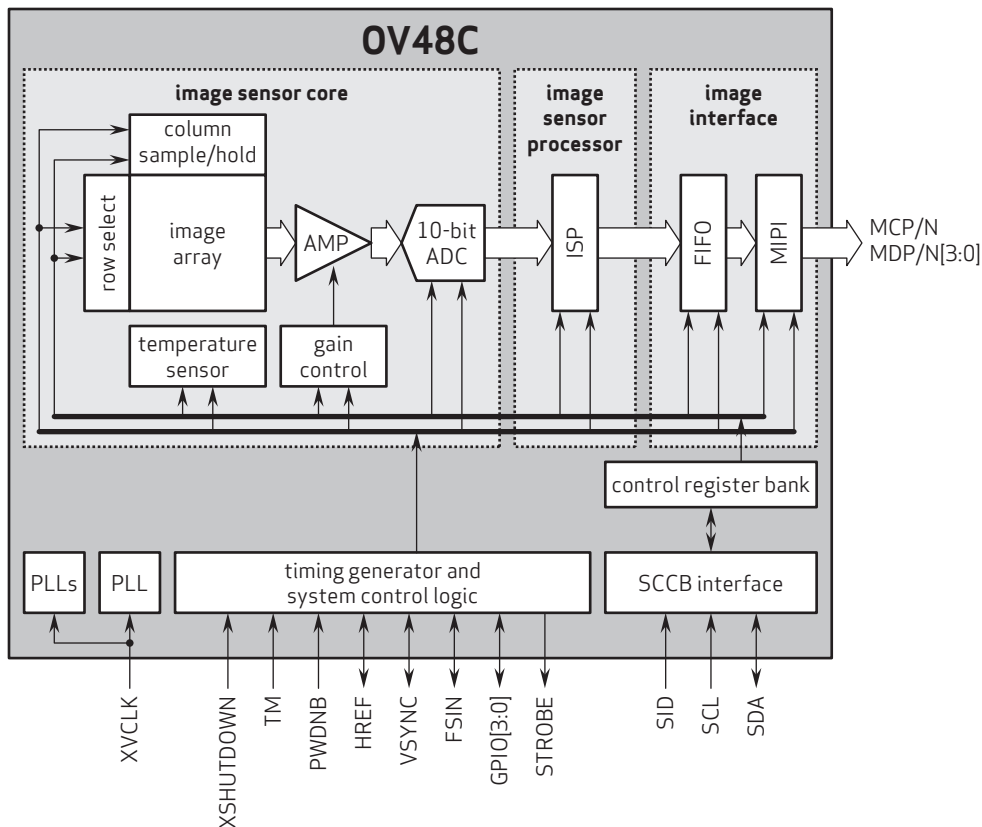

4275 Burton Drive
Santa Clara, CA 95054
USA

Tel: +1 408 567 3000
Fax: +1 408 567 3001
www.ovt.com

OmniVision reserves the right to make changes to their products or to discontinue any product or service without further notice. OmniVision, the OmniVision logo and PureCel are registered trademarks of OmniVision Technologies, Inc. All other trademarks are the property of their respective owners.



OmniVision