

# OV13B10 13MP product brief



## 1/3-inch 13MP Image Sensor for Mainstream and Entry-Level Smartphone Cameras



available in  
a lead-free  
package

The OmniVision OV13B image sensor is the latest addition of our widely deployed 13MP family, featuring a 1/3-inch optical format and ultra-low power consumption. Built with our PureCel®Plus pixel technology, the OV13B provides mainstream and entry-level smartphone designers with the industry's best 1.12 micron pixel performance for rear- or front-facing cameras. This sensor will not only fulfill the tremendous demand in the mainstream market, but can also boost the performance of entry-level smartphones. Additionally, it is a perfect fit for both wide-angle and telephoto cameras in multi-camera configurations.

In comparison with its predecessors, the OV13B has significantly lower power consumption for extended battery life. It also has a smaller chip size, enabling an

8.5 mm x 8.5 mm autofocus module for main cameras, or a 6.4 mm x 7.2 mm fixed focus module for front-facing cameras with a Z height below 4 mm.

The OV13B image sensor supports phase detection autofocus (PDAF), while providing multiple resolution options to meet the needs of end users, including full-resolution 13MP image output at 30 frames per second (fps), 4K2K video at 30 fps, 1080p full high definition (HD) at 60 fps, or 720p HD at 120 fps.

Find out more at [www.ovt.com](http://www.ovt.com).



## Applications

- Smart Phones and Feature Phones
- Tablets
- PC multimedia
- Wearables

## Product Features

- 1.12  $\mu\text{m}$  x 1.12  $\mu\text{m}$  pixel
- optical size of 1/3.06"
- 33.25° CRA
- support for phase detection auto focus (PDAF)
- 13MP at 30 fps
- programmable controls for:
  - frame rate
  - mirror and flip
  - cropping
  - windowing
- supports images sizes:
  - 13MP (4208x3120)
  - 10MP (4208x2368)
  - 3MP (2104x1560)
  - 1080p, and more
- support for output formats:
  - 10-bit RAW RGB
- total embedded one-time programmable (OTP) memory: 512 bytes
- two-wire serial bus control (SCCB)
- MIPI serial output interface (1-lane, 2-lane, or 4-lane)
- two on-chip phase lock loops (PLLs)
- 2x binning support
- image quality controls:
  - defect pixel correction (DPC)
  - automatic black level calibration (ABLC)
- suitable for module size of 8.5 x 8.5 x <math>5\text{ mm}</math>

# OV13B10

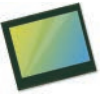

## Ordering Information

- OV13B10-GA5A**  
(color, chip probing, 150  $\mu\text{m}$  backgrinding, reconstructed wafer with good die)

## Technical Specifications

- active array size:** 4208 x 3120
- maximum image transfer rate:**
  - 13MP (4208x3120): 30 fps
  - 10MP (4208x2368): 30 fps
  - 3MP (2104x1560): 60 fps
  - 1080p (1920x1080): 60 fps
- power requirements:**
  - active: 194 mW
  - standby: 1 mW
  - XSHUTDOWN: 1  $\mu\text{W}$
- power supply:**
  - analog: 2.7 to 2.9V (2.8V nominal)
  - core: 1.14 to 1.26V (1.2V nominal)
  - I/O: 1.7 to 1.9V (1.8V nominal)
- temperature range:**
  - operating: -30°C to +85°C junction temperature
  - stable image: 0°C to +60°C junction temperature
- output interface:** 4-lane MIPI serial output
- output format:** 10-bit RGB RAW
- lens size:** 1/3.06"
- lens chief ray angle:** 33.25° non-linear
- pixel size:** 1.12  $\mu\text{m}$  x 1.12  $\mu\text{m}$
- image area:** 4713.984  $\mu\text{m}$  x 3499.776  $\mu\text{m}$

## Functional Block Diagram

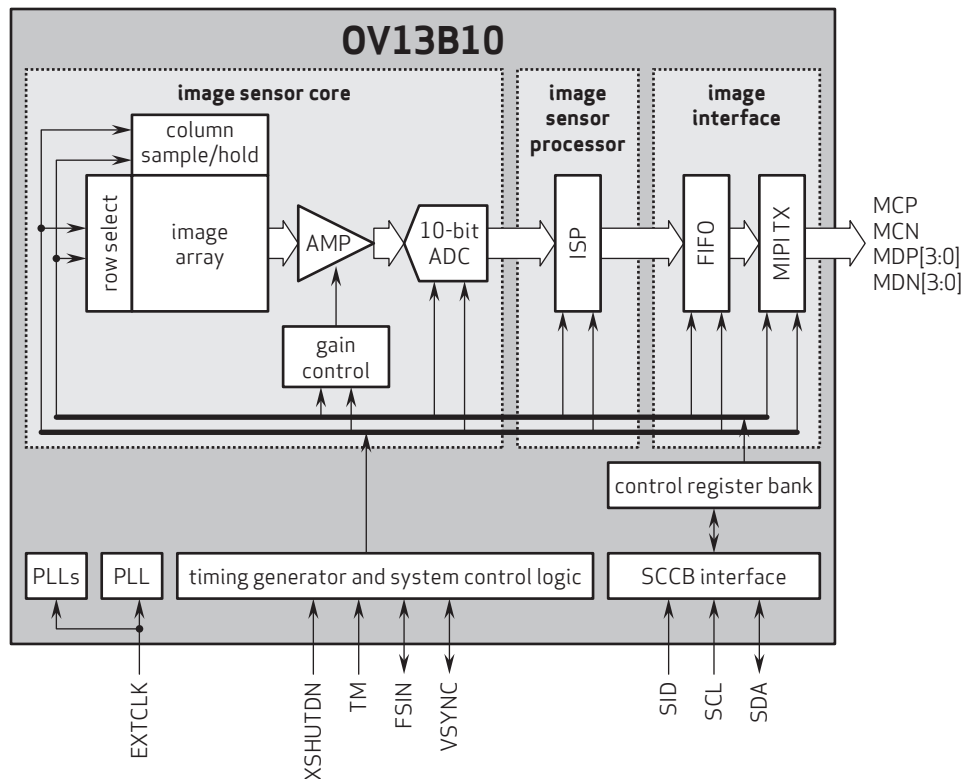

4275 Burton Drive  
Santa Clara, CA 95054  
USA

Tel: + 1 408 567 3000  
Fax: + 1 408 567 3001  
www.ovt.com

OmniVision reserves the right to make changes to their products or to discontinue any product or service without further notice. OmniVision, the OmniVision logo and PureCel are registered trademarks of OmniVision Technologies, Inc. All other trademarks are the property of their respective owners.



OmniVision