

OV13A10 13MP product brief



available in
a lead-free
package

High-Performance 13-Megapixel PureCel®Plus-S Image Sensor Optimized for Dual-Camera Smartphone Applications

OmniVision's OV13A10 is an ultra-compact 13-megapixel image sensor built on OmniVision's second-generation, 1.0-micron PureCel®Plus-S stacked die pixel technology. Designed specifically for dual-camera applications, the OV13A10 achieves a z-height of less than 6 mm, meeting the compact space requirements of next-generation smartphones.

A customized chief ray angle (CRA) enables the OV13A10 to be used as a tele-sensor in a 2x optical zoom configuration, which offers DSLR-like image quality and user experience. The OV13A10 is also optimized for dual-camera zoom solutions, with features such as context switching and frame synchronizing to simplify camera system architecture.

The OV13A10 brings a host of advanced imaging capabilities to smartphones, including zigzag high dynamic range (zHDR) and phase-detection autofocus (PDAF), which extends the sensor's dynamic range capabilities and enables snap-quick autofocus, respectively. The sensor supports multiple resolution and frame-rate configurations, including full-resolution 13-megapixel images and video at 30 frames per second (fps) with zHDR, 4K2K video at 30 fps, and 1080p video at 60 fps.

Find out more at www.ovt.com.



Applications

- Smartphones
- Video Conferencing
- PC Multimedia

Product Features

- 13MP @ 30 fps, 4K2K @ 30 fps
- supports phase detection auto focus (PDAF) pixels with bypass PD pixels
- supports dynamic defect pixel correction (DPC)
- automatic black level calibration (ABLC)
- total embedded one-time programmable (OTP) memory: 1536 bytes
- supports typical images sizes:
 - 4224x3136
 - 4224x2376
 - 2112x1568
 - 2112x1188
 - 1408x792
- supports horizontal and vertical subsampling
- programmable I/O drive capability
- supports ZigZag HDR timing
- programmable controls for:
 - frame rate
 - mirror and flip
 - cropping
 - windowing
- up to 4-lane MIPI TX interface with speed up to 1.2 Gbps/lane
- standard serial SCCB interface with speed up to 1 MHz (when clock input is >10 MHz)
- supports output formats:
 - 10-bit RAW RGB
 - DPCM 10-8 compression
- long exposure time of up to 30 seconds
- two on-chip phase lock loops (PLLs)
- built-in temperature sensor
- typical module size: 8.5 x 8.5 x 0.6 mm

OV13A10



Ordering Information

- OV13A10-GA5A-Z**
(color, chip probing, 150 μ m backgrinding, reconstructed wafer with good die)

Technical Specifications

- active array size:** 4224 x 3136
- maximum image transfer rate:**
 - 4224 x 3136: 30 fps
 - 4224 x 2376: 30 fps
 - 2112 x 1568: 60 fps
 - 2112 x 1188: 60 fps
 - 1408 x 792: 60 fps
- temperature range:**
 - operating: -30°C to +85°C junction temperature
 - stable image: 0°C to +60°C junction temperature
- pixel size:** 1.008 μ m x 1.008 μ m
- lens size:** 1/3.4"
- lens chief ray angle:** 29.48° non-linear
- scan mode:** progressive
- image area:** 4290.05 μ m x 3193.34 μ m
- power supply:**
 - core: 1.2V
 - analog: 2.8V
 - I/O: 1.8V
- power requirements:**
 - active: 228 mW
 - standby: 1.2 mW
 - XSHUTDOWN: <math><20</math> μ A

Functional Block Diagram

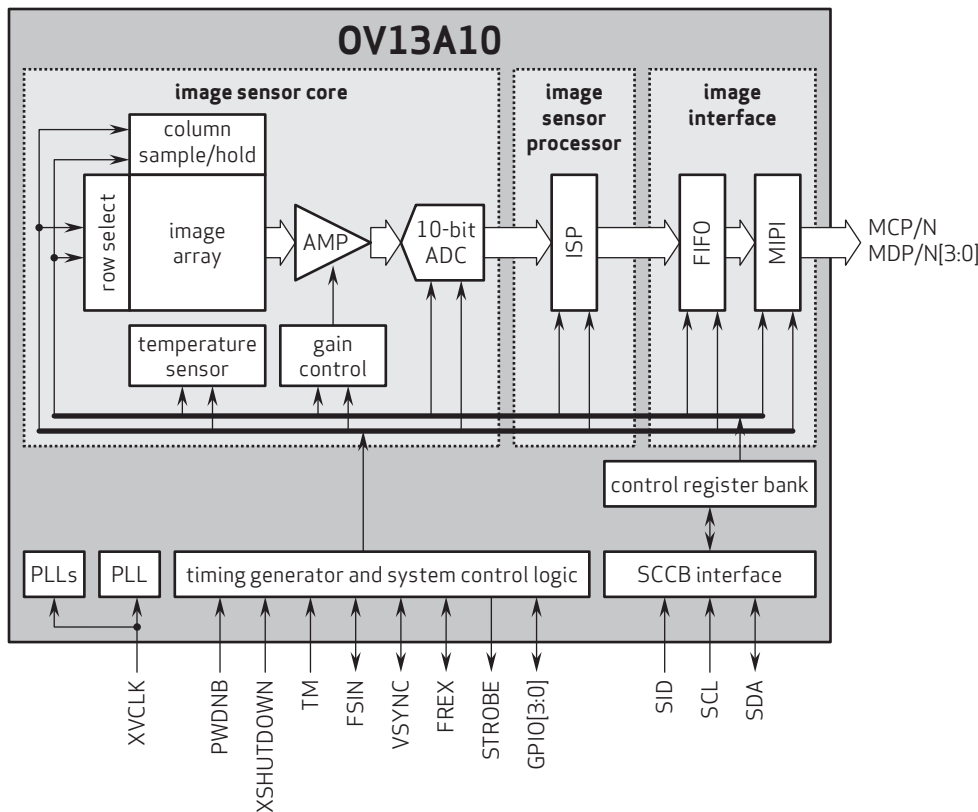

4275 Burton Drive
Santa Clara, CA 95054
USA

Tel: + 1 408 567 3000
Fax: + 1 408 567 3001
www.ovt.com

OmniVision reserves the right to make changes to their products or to discontinue any product or service without further notice. OmniVision, the OmniVision logo and PureCel are registered trademarks of OmniVision Technologies, Inc. All other trademarks are the property of their respective owners.



OmniVision