

OS08A20 8-megapixel product brief



available in
a lead-free
package

High Resolution 8-Megapixel PureCel® Sensor Brings Superior Near-Infrared Imaging to Surveillance Applications

OmniVision's OS08A20 is the first 8-megapixel image sensor to combine Nyxel® technology with OmniVision's PureCel® pixel architecture, which allows the OS08A20 to capture ultra-high definition (UHD) 4K2K video and images that are bright and crisp in all lighting conditions. This makes it an ideal imaging solution for professional surveillance systems, as well as other nascent security applications such as body-worn cameras.

OmniVision's breakthrough Nyxel® technology delivers significant quantum efficiency (QE) improvements at 850 nm and 940 nm while maintaining high-modulation transfer function, allowing the OS08A20 to monitor a larger area. Additionally, by reducing the need for external lighting sources, Nyxel® technology enables lower power consumption.

The OS08A20 supports a wide range of resolution formats and frame rates, including 4K2K (3840x2160) in a 16:9 aspect ratio at 60 frames per second (fps), quad HD (2560x1440) at 60 fps, or full 1080p HD at 120 fps. It comes in a 2x2-micron pixel size and 1/1.8-inch optical format for improved sensitivity.

Find out more at www.ovt.com.



Applications

- Security Cameras
- Action Cameras
- High Resolution Consumer Cameras
- Digital Still Cameras (DSC)
- Digital Video Camcorders (DVC)

Product Features

- 2 μm x 2 μm pixel
- optical size of 1/1.8"
- QE enhancement in 850 nm and 940 nm
- programmable controls for:
 - frame rate
 - mirror and flip
 - cropping
 - windowing
- supports output formats:
 - 12-/10-bit RAW RGB
- supports image sizes:
 - 4K2K (3840x2160)
 - 2560 x 1440
 - 1080p (1920x1080)
 - 720p (1280x720)
- supports 2x2 binning
- standard serial SCCB interface
- 12-bit ADC
- up to 4-lane MIPI/LVDS serial output interface (supports maximum speed up to 1500 Mbps/lane)
- 2-exposure staggered HDR support
- programmable I/O drive capability
- light sensing mode (LSM)
- PLL with SCC support
- support for FSIN

OS08A20



Ordering Information

- OS08A20-H92A-1B (color, lead-free)
92-pin CSP

Technical Specifications

- active array size: 3840 x 2160
- maximum image transfer rate:
 - 4K2K: 60 fps
 - 2560 x 1440: 60 fps
 - 1080p: 120 fps
- power supply:
 - core: 1.2V
 - analog: 2.8V
 - I/O: 1.8V
- power requirements:
 - active: 240 mA
 - XSHUTDOWN: <math><10 \mu\text{A}</math>
- temperature range:
 - operating: -30°C to +85°C junction temperature
 - stable image: 0°C to +60°C junction temperature
- output formats: 10/12-bit RGB RAW
- lens size: 1/1.8"
- lens chief ray angle: 11° linear
- scan mode: progressive
- pixel size: 2.0 μm x 2.0 μm
- image area: 7736.256 μm x 4379.616 μm

Functional Block Diagram

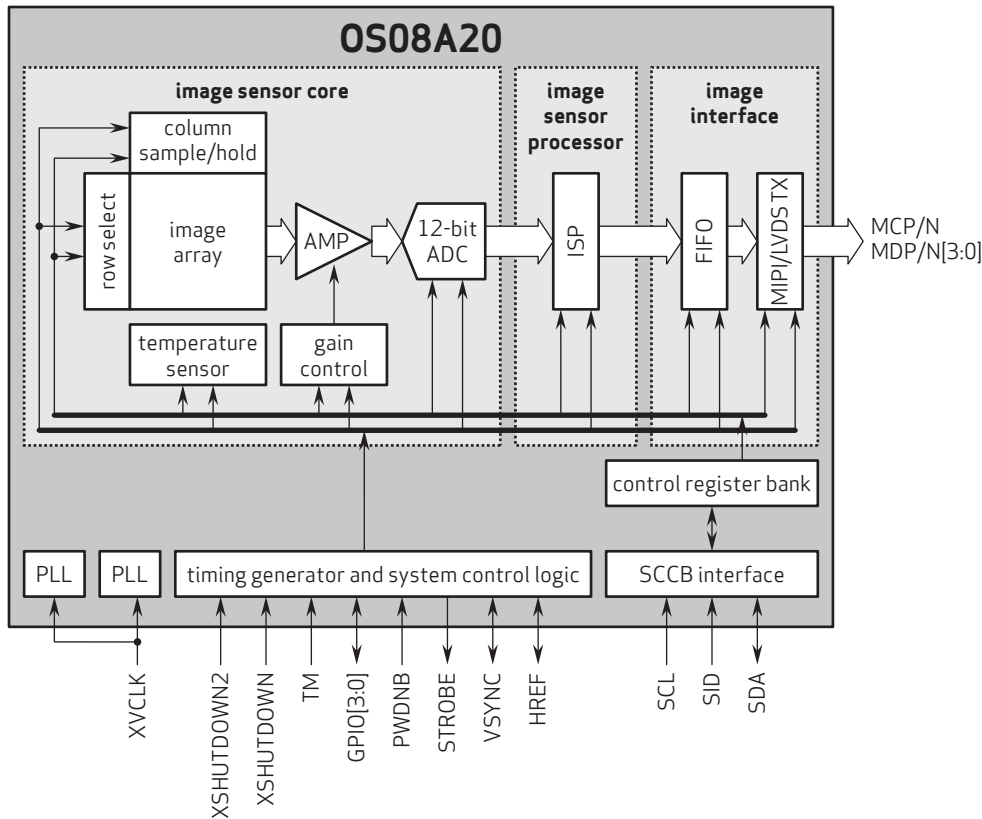

4275 Burton Drive
Santa Clara, CA 95054
USA

Tel: + 1 408 567 3000
Fax: + 1 408 567 3001
www.ovt.com

OmniVision reserves the right to make changes to their products or to discontinue any product or service without further notice. OmniVision, the OmniVision logo, PureCel, and Nyxel are registered trademarks of OmniVision Technologies, Inc. All other trademarks are the property of their respective owners.



OmniVision