

# OV32B 32MP product brief



## 32MP Image Sensor for Smartphone Front Cameras with Compact 1/3" Optical Format and 0.7 Micron Pixel



available in  
a lead-free  
package

OmniVision's OV32B is a 32MP, 0.7 micron pixel image sensor with a 1/3" optical format that enables smartphone designers to offer the highest possible front-facing camera resolution in the limited space available. The OV32B supports 2- and 3-exposure HDR timing for up to 8MP video modes and still previews. Additionally, it integrates a 4-cell color filter array and on-chip hardware re-mosaic, which provides high quality, 32MP Bayer output in real time—a feature that normally would be difficult to achieve in the 1/3" optical format.

The OV32B is built on OmniVision's PureCel®Plus stacked die technology, providing leading-edge still image captures and exceptional 1080p video recordings at 180 frames per second (fps). In low light conditions, this sensor can use near-pixel binning to output an 8MP image with 4X the sensitivity, offering 1.4 micron pixel equivalent performance for previews and still captures. The OV32B can also consistently capture the best

quality images while enabling seamless fast mode switch and multicamera sync. In addition to front-facing cameras, these features are also ideal for rear-facing telephoto smartphone cameras.

To boost autofocus accuracy, especially in low light, the OV32B offers the option to integrate type-2, 2x2 microlens phase detection autofocus (ML-PDAF). It also provides a CPHY interface for greater throughput using fewer pins, as well as a DPHY interface. Output formats include 32MP at 15 fps, 8MP at 60 fps and 6MP (16:9) at 90 fps—all with 4-cell binning. Additionally, the sensor can output 1080p video at 120 fps, 1.5MP captures (16:9) at 240 fps and 720p video at 360 fps.

Find out more at [www.ovt.com](http://www.ovt.com).



**OmniVision**

## Applications

- Smart Phones
- Video Conferencing
- PC Multimedia

## Product Features

- automatic black level calibration (ABLC)
- programmable controls for:
  - frame rate
  - mirror and flip
  - binning
  - cropping
  - windowing
- support for dynamic defect pixel cancellation (DPC)
- supports output formats:
  - 10-bit RGB 4-cell (4C) non-HDR
  - 10-bit RGB Bayer non-HDR
- supports horizontal and vertical subsampling
- supports typical images sizes:
  - 6528 x 4896
  - 3264 x 2448
  - 1632 x 918
  - 1920 x 1080
  - 1280 x 720
- standard serial SCCB interface
- 2/3 trio C-PHY interface, up to 2.45 Gbps/trio
- built-in temperature sensor
- up to 4-lane MIPI TX interface with speed up to 3.0 Gbps/lane
- 4-cell support:
  - 4-cell binning
  - 4-cell full
- HDR support:
  - stagger HDR 2/3 exposure timing
- on-chip 4-cell to Bayer converter
- three on-chip phase lock loops (PLLs)
- programmable I/O drive capability
- supports type 2x2 ML PDAF
- 0.702  $\mu\text{m}$  pixel

# OV32B



## Ordering Information

- OV32B40-GA5A-002A-Z  
(color, chip probing, 150  $\mu\text{m}$  backgrinding, reconstructed wafer with good die)

## Technical Specifications

- active array size: 6528 x 4896
- maximum image transfer rate:
  - 1280p: 60 fps
- power supply:
  - core: 1.1V
  - analog: 2.8V
  - I/O: 1.8V
- power requirements:
  - XSHUTDOWN: <10  $\mu\text{A}$
- temperature range:
  - operating: -30°C to +85°C junction temperature
  - stable image: 0°C to +60°C junction temperature
- lens size: 1/3.14"
- lens chief ray angle: 35.06° non-linear
- output formats:
  - 10-bit RGB 4C non-HDR
  - 10-bit RGB Bayer non-HDR
- scan mode: progressive
- pixel size: 0.702  $\mu\text{m}$  x 0.702  $\mu\text{m}$
- image area: 4605.12  $\mu\text{m}$  x 3459.456  $\mu\text{m}$

## Functional Block Diagram

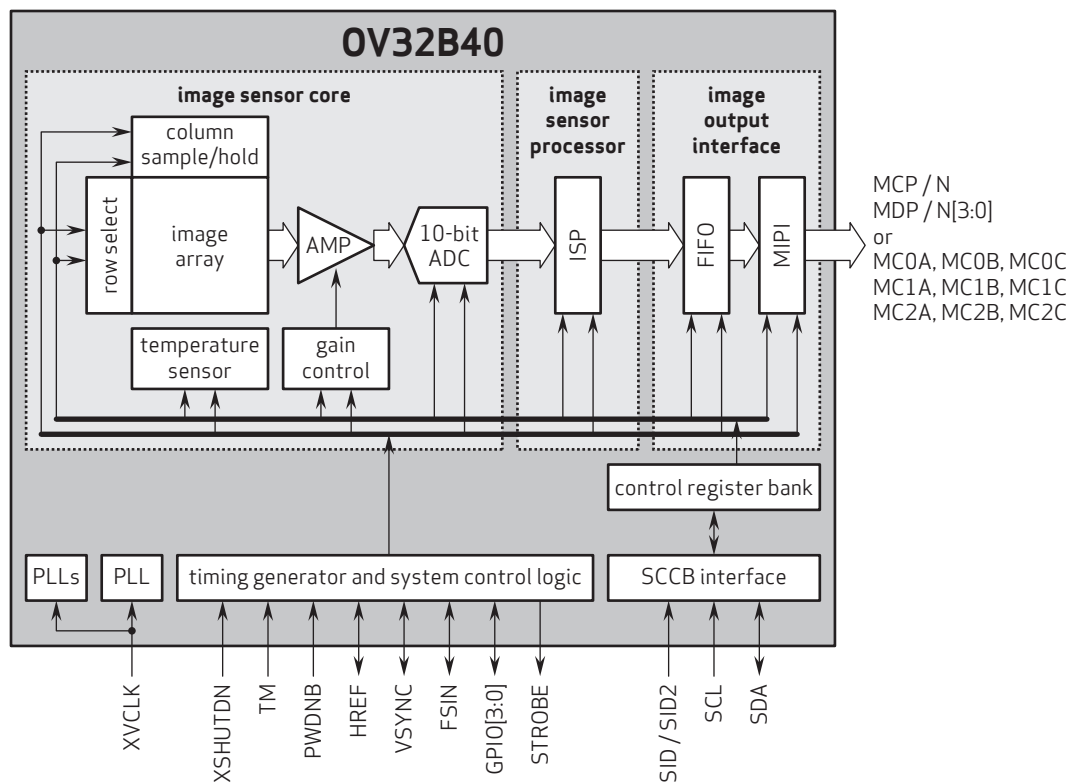

4275 Burton Drive  
Santa Clara, CA 95054  
USA

Tel: + 1 408 567 3000  
Fax: + 1 408 567 3001  
www.ovt.com

OmniVision reserves the right to make changes to their products or to discontinue any product or service without further notice. OmniVision, the OmniVision logo, and PureCel are registered trademarks of OmniVision Technologies, Inc. All other trademarks used herein are the property of their respective owners.



OmniVision