

OX03C10 2.5MP product brief



Image Sensor for Automotive Viewing Cameras with 140 dB HDR and Top LED Flicker Mitigation Performance



available in
a lead-free
package

OmniVision's OX03C10 is a 2.5 Megapixel (MP), ASIL-C image sensor. It provides automotive viewing applications with the combination of a large 3.0 micron pixel size, a high dynamic range (HDR) of 140 dB and the best LED flicker mitigation (LFM) performance for minimized motion artifacts. Additionally, the integration of OmniVision's industry-leading HALE (HDR and LFM engine) combination algorithm uniquely provides top HDR and LFM performance simultaneously. These industry-leading features enable the best image quality for automotive viewing applications, including rearview cameras (RVC), surround view systems (SVS), camera monitoring systems (CMS) and e-mirrors.

Built on OmniVision's PureCel®Plus stacked die technology, this sensor enables pixel performance advantages over non-stacked technology. 3D stacking boosts pixel and dark current performance, resulting in a 20% improvement in the signal-to-noise ratio over the prior generation of its 2.5MP viewing sensors.

The OX03C10 is also the first viewing image sensor with HDR and LFM that can deliver 1920 x 1280p resolution at the highest rate of 60 frames per second (fps), enabling greater design

flexibility and faster camera-view switching for drivers. Additionally, it has the lowest power consumption of any LFM image sensor with 2.5MP resolution, along with the industry's smallest package size, enabling the placement of cameras that continuously run at 60 fps in even the tightest spaces for stringent styling requirements.

The sensor uses OmniVision's Deep Well™, dual conversion gain (DCG) technology to provide significantly lower motion artifacts. Additionally, split-pixel LFM technology with four captures provides the best performance over the entire automotive temperature range.

The OX03C10 features 4-lane MIPI CSI-2 and 12-bit DVP interfaces and is available in both a-CSP™ and a-BGA™ packages.

Find out more at www.ovt.com.



OmniVision

Applications

- Automotive
 - Surround View System
 - Rear View Camera
- Autonomous Driving
- E-Mirror

Product Features

- support for image size: 1920 x 1280 and any cropped size
- PureCel[®]Plus-S technology
- HDR readout modes, with up to 4x captures and on-chip combination:
 - on-chip line buffers (alignment with staggered readout)
 - DCG (LPD) + SPD + staggered (VS)
 - DCG (LPD) + staggered (VS)
 - LFM support (SPD)
 - PWL mapping from 24-bit to 20, 16, 14, and 12-bit
- motion free HDR (3 capture), 4 capture HDR optimized to minimize motion artifacts
- SCCB for register programming
- high speed serial data transfer with MIPI CSI-2
- image signal processor functions:
 - lens shading correction
 - defective pixel cancellation
 - HDR combination
 - automatic black level correction
 - PWL compression, etc.
- safety features for supporting ASIL C applications
- parallel 12-bit DVP output
- external frame synchronization capability
- embedded temperature sensor
- embedded supply voltage monitor
- one-time programmable (OTP) memory

OX03C10



Ordering Information

- **OX03C10-B83Y-001B-Z**
(color, lead-free) 83-pin a-BGA™ packed in tray without protective film

Technical Specifications

- **active array size:** 1920 x 1280
- **maximum image transfer rate:**
 - 1280p: 60 fps
- **power supply:**
 - analog: 2.9V
 - digital: 1.1V
 - I/O pads: 1.8V/3.3V
- **power requirements:**
 - active: streaming @ 1280p60: 390 mW (HDR4 combined 24b), streaming @ 1280p30: 290 mW (HDR4 combined 24b)
- **temperature range:**
 - operating: -40°C to +105°C sensor ambient temperature and -40°C to +125°C junction temperature
- **output interfaces:** up to 4-lane MIPI CSI-2, 12-bit DVP
- **lens size:** 1/2.6"
- **lens chief ray angle:** 20°
- **output formats:** uncompressed 24-bit, 20/16/14/12-bit (PWL) combined HDR (4 captures)
- **pixel size:** 3 μm x 3 μm
- **image area:** 5814 μm x 3894 μm

Functional Block Diagram

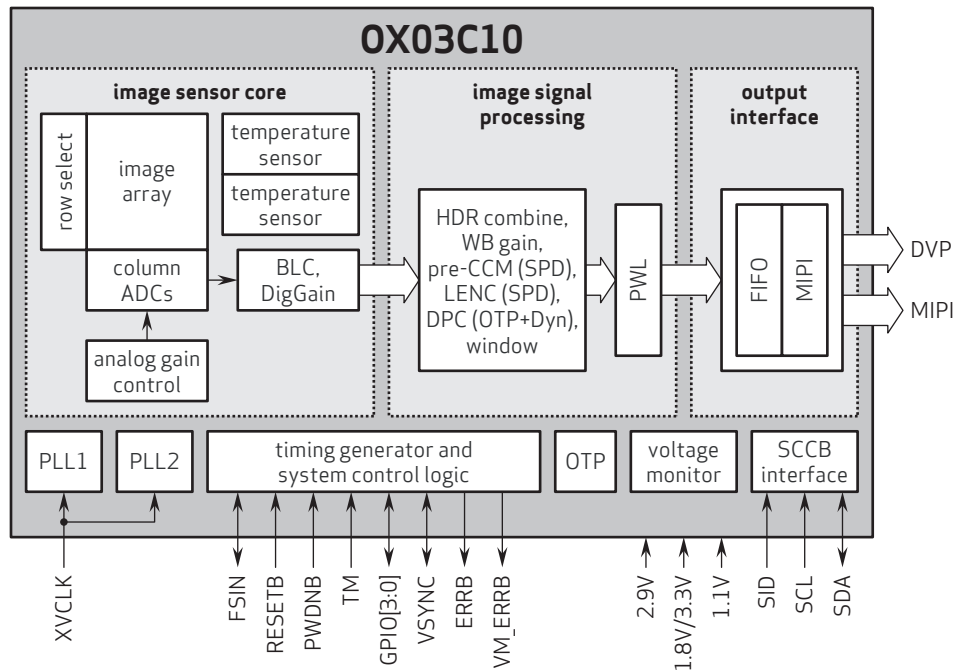

4275 Burton Drive
Santa Clara, CA 95054
USA

Tel: + 1 408 567 3000
Fax: + 1 408 567 3001
www.ovt.com

OmniVision reserves the right to make changes to their products or to discontinue any product or service without further notice. OmniVision, the OmniVision logo, and PureCel are registered trademarks of OmniVision Technologies, Inc. Deep Well, a-CSP, and a-BGA are trademarks of OmniVision Technologies, Inc. All other trademarks used herein are the property of their respective owners.



OmniVision