

OS05A20 5-megapixel product brief



available in
a lead-free
package

New OS05A20 Uses Nyxel™ Technology to Bring Superior Image Quality to Video Surveillance Cameras Day or Night

The 5-megapixel OS05A20 is the world's first image sensor to implement Nyxel™ technology, OmniVision's breakthrough near-infrared (NIR) technology that allows image sensors to see better and farther under low- and no-light conditions. By using Nyxel technology and a 2 x 2 micron pixel, the OS05A20 PureCel® image sensor has the unique ability to capture high-quality, high-resolution day or night, making it ideally suited for professional surveillance systems.

Nyxel technology combines thick-silicon pixel architectures with extended deep trench isolation (DTI) to improve quantum efficiency (QE) up to 3x for 850 nm sensitivity and up to 5x for 940 nm sensitivity, while

maintaining all other image-quality metrics. These improvements deliver unrivaled image quality, extended image-detection range and a reduced light-source requirement, leading to lower power consumption.

Available in a 1/2.7-inch optical format, the OS05A20 is capable of capturing full-resolution 2688 x 1944 video at 60 frames per second (fps), 1080p full high definition (HD) video at 120 fps, and 720p HD video at 180 fps. The sensor comes in a 6.6 x 5.9 mm chip scale package (CSP).

Find out more at www.ovt.com.



Applications

- Security Cameras
- High Resolution Consumer Cameras
- Action Cameras

Product Features

- 2 μm x 2 μm pixel
- optical size of 1/2.7"
- QE enhancement in 850 nm and 940 nm
- programmable controls for:
 - frame rate
 - mirror and flip
 - cropping
 - windowing
- supports output formats:
 - 12-/10-bit RAW RGB
- supports images sizes:
 - 2688 x 1944
 - 1080p (1920x1080)
 - 720p (1280x720)
- supports 2x2 binning
- standard serial SCCB interface
- 12/10-bit ADC
- up to 4-lane MIPI/LVDS serial output interface (supports maximum speed up to 1500 Mbps/lane)
- 2-exposure staggered HDR support
- programmable I/O drive capability
- light sensing mode (LSM)
- PLL with SCC support
- support for frame sync

OS05A20



Ordering Information

- OS05A20-H73A-1B
(color, lead-free) 73-pin CSP

Product Specifications

- active array size: 2688 x 1944
- lens chief ray angle: 11° linear
- power supply:
 - core: 1.2V
 - analog: 2.8V
 - I/O: 1.8V
- max S/N ratio: 39 dB
- dynamic range: 74 dB @ 16x gain
- power requirements:
 - active: 210 mW
 - standby: 2 mA
 - XSHUTDOWN: 2 μA
- maximum image transfer rate:
 - 2688 x 1944: 60 fps
 - 2688 x 1520: 60 fps
- sensitivity: 14,000 e⁻/Lux-sec
- temperature range:
 - operating: -30°C to +85°C junction temperature
 - stable image: 0°C to +60°C junction temperature
- scan mode: progressive
- output formats: 10/12-bit RGB RAW
- maximum exposure interval: VTS - 8
- minimum exposure interval: 4 t_{ROW}
- lens size: 1/2.7"
- pixel size: 2.0 μm x 2.0 μm
- image area: 5434.56 μm x 3948.05 μm
- input clock frequency: 6 - 27 MHz
- package dimensions:
 - CSP: 6628 μm x 5925 μm

Functional Block Diagram

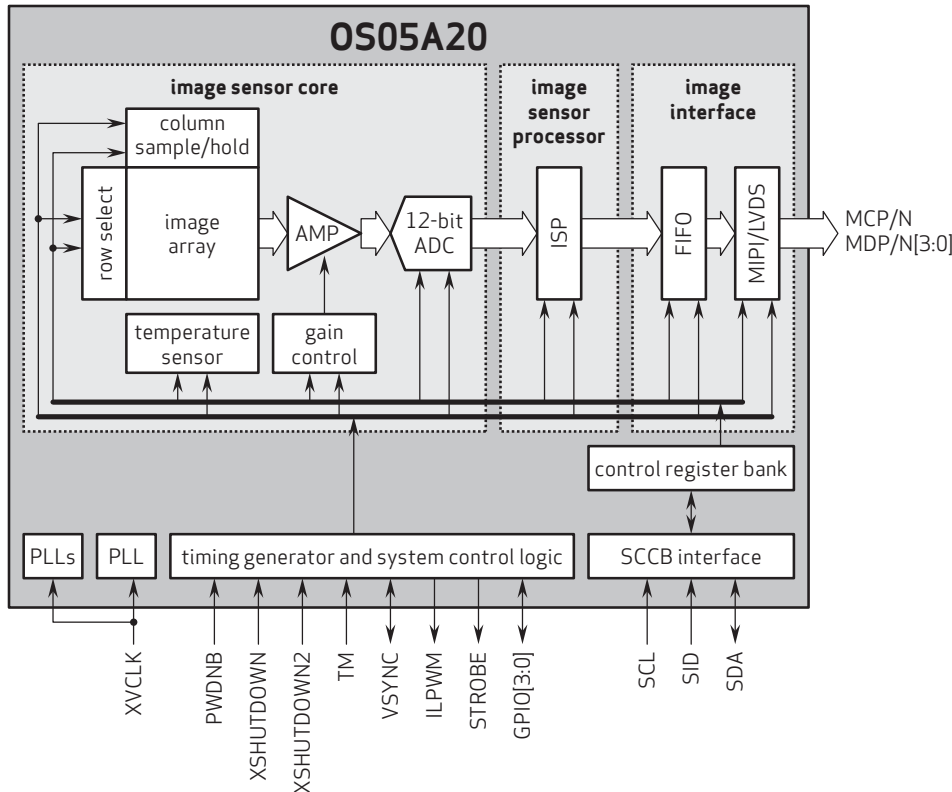

4275 Burton Drive
Santa Clara, CA 95054
USA

Tel: + 1 408 567 3000
Fax: + 1 408 567 3001
www.ovt.com

OmniVision reserves the right to make changes to their products or to discontinue any product or service without further notice. OmniVision, the OmniVision logo and PureCel are registered trademarks of OmniVision Technologies, Inc. Nyxel is a trademark of OmniVision Technologies, Inc. All other trademarks are the property of their respective owners.



OmniVision