

OV9716 1.4MP product brief



1.4-Megapixel Image Sensor with Best-in-Class Performance for Cost-Effective Automotive Applications



available in
a lead-free
package

OmniVision's OV9716 is a high-performance image sensor that brings 1392 x 976 resolution at up to 60 frames per second with more than 120 dB dynamic range to automotive imaging applications. The sensor comes in a 1/3.8-inch optical format and is built on 2.8-micron OmniBSI-2™ Deep Well™ pixel technology, which delivers best-in-class low-light sensitivity and high dynamic range (HDR) performance even in challenging lighting conditions. The OV9716 is specifically designed to bring the performance of a high-end imaging solution at a cost and form factor suitable for the automotive mass market segment, targeting rear view cameras and 360-degree surround view systems.

The OV9716's Deep Well™ pixel technology provides a 16-bit linear output, capturing 94 dB of scene dynamic range in a single frame, compared to traditional sensors with only 12-bit linear output. This 94 dB output comes

without HDR combination artifacts and has no sudden drops in signal-to-noise ratio across the scene. The sensor can further expand dynamic range to more than 120 dB by using a second 'very short' exposure, also minimizing motion artifacts.

The OV9716 is available in an AEC-Q100 Grade 2-qualified, compact 5.8 x 5.25 mm chip scale package and contains an advanced set of safety mechanisms to enable ISO 26262 ASIL B-rated camera systems. The sensor is compatible with OmniVision's family of powerful image signal processor (ISP) companion chips for display-based automotive applications.

Find out more at www.ovt.com.



OmniVision

Applications

- automotive
 - 360° surround view system
 - rear view camera
 - lane departure warning/ lane keep assist
 - blind spot detection
- pedestrian detection
- traffic sign recognition
- occupant sensor
- camera monitoring system/e-mirror
- autonomous driving

Product Features

- support for image size:
 - 1392 x 976
 - VGA
 - QVGA, and any cropped size
- high dynamic range
- high sensitivity
- low power consumption
- image sensor processor functions:
 - lens correction
 - defective pixel cancelation
 - HDR combination
 - automatic black level correction
- supported output formats:
 - RAW
- horizontal and vertical sub-sampling
- SCCB for register programming
- high speed serial data transfer with MIPI CSI-2
- parallel 12-bit DVP output
- external frame synchronization capability
- embedded temperature sensor
- one time programmable (OTP) memory

OV9716

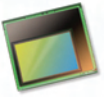

Ordering Information

- **OV09716-E66Y-1G** (color, lead-free) 66-pin a-CSP™ with DAR coating, in tray
- **OV09716-E66Y-LG** (color, lead-free) 66-pin a-CSP™ with DAR coating, packed in tray with protective film (3 mm tab length)
- **OV09716-E66Y-OG** (color, lead-free) 66-pin a-CSP™ with DAR coating, packed in tape and reel with protective film (3 mm tab length)
- **OV09716-E66Y-GG** (color, lead-free) 66-pin a-CSP™ with DAR coating, packed in tray with protective film (0.5 mm tab length)
- **OV09716-E66Y-KG** (color, lead-free) 66-pin a-CSP™ with DAR coating, packed in tape and reel with protective film (0.5 mm tab length)

Product Specifications

- **active array size:** 1392 x 976
- **power supply:**
 - **SVDD, SVDD_{pix}, PVDD (analog):** 3.14 - 3.47V
 - **DVDD (digital):** 1.14 - 1.3V
 - **DOVDD (digital):** 1.7 - 1.9V
 - **AVDD18 (analog):** 1.7 - 1.9V
- **power requirements:**
 - active: 288 mW
 - standby: 12.5 mW
- **temperature range:**
 - operating: -40°C to +105°C sensor ambient temperature and -40°C to +125°C junction temperature
- **output interfaces:** up to 4-lane MIPI CSI-2, 12-bit DVP
- **input clock frequency:** 6 - 36 MHz
- **lens size:** 1/3.8"
- **lens chief ray angle:** 15°
- **output formats:** single exposure HDR - 16-bit combined RAW, 12-bit compressed combined RAW; dual exposure HDR - 16-bit combined RAW + 12-bit VS RAW, 12-bit compressed combined RAW + 12-bit VS RAW, 3x12 bit RAW, 3x10 bit RAW
- **scan mode:** progressive
- **shutter:** rolling shutter
- **maximum image transfer rate:** 60 fps full resolution
- **sensitivity:** 27,500 e⁻/Lux-sec
- **max S/N ratio:** 41 dB
- **dynamic range:** 120 dB
- **pixel size:** 2.8 μm x 2.8 μm
- **image area:** 3942.4 μm x 2777.6 μm
- **package dimensions:**
 - a-CSP™: 5814 μm x 5254 μm

Functional Block Diagram

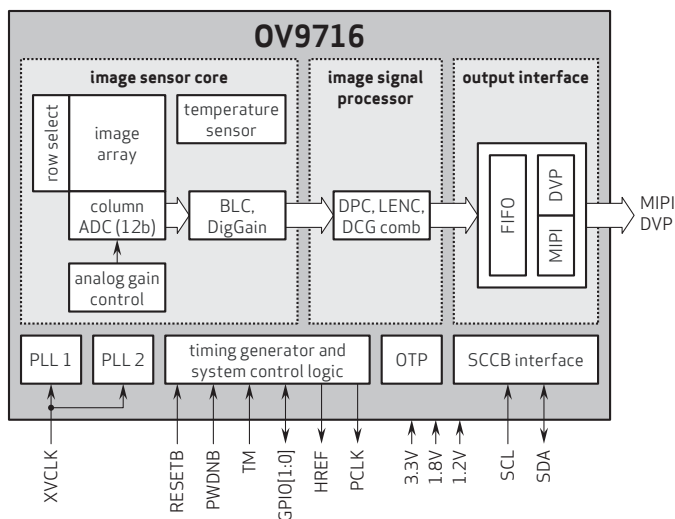

4275 Burton Drive
Santa Clara, CA 95054
USA

Tel: + 1 408 567 3000
Fax: + 1 408 567 3001
www.ovt.com

OmniVision reserves the right to make changes to their products or to discontinue any product or service without further notice. OmniVision and the OmniVision logo are registered trademarks of OmniVision Technologies, Inc. OmniBSI-2, Deep Well and a-CSP are trademarks of OmniVision Technologies, Inc. All other trademarks are the property of their respective owners.



OmniVision