

OV16860 16MP product brief



Fast Frame Rate 16-Megapixel PureCel® Plus-S Sensor for Smartphones and Action Cameras



available in
a lead-free
package

OmniVision's OV16860 is a high performance 16-megapixel PureCel Plus-S image sensor designed for high-end smartphones and action cameras. Compared to previous generation 16-megapixel sensors, the OV16860 delivers improved low-light performance and faster readout architecture with a larger 1.3-micron pixel, enabling full resolution recording at 45 frames per second (fps). The sensor also supports advanced features such as high dynamic range (HDR), and phase detection autofocus (PDAF).

OmniVision's new PureCel Plus-S architecture and larger pixel size offer a number of pixel performance improvements over traditional 1.12-micron 16-megapixel sensors, including a 33 percent

improvement in full-well capacity, a 40 percent improvement in low light performance and dramatically reduced pixel crosstalk.

The 1/2.4-inch OV16860 supports high-quality slow motion video capture with full field of view (FOV). The sensor can capture 16-megapixel images and video at 45 fps, ultra-high resolution 4K2K video at 60 fps, and 1080p high definition (HD) video at 120 fps via high speed D-PHY and C-PHY interfaces. Additionally, the OV16860 combines advance process and design optimization to enable nominal operating digital voltage (DVDD) spec of 1.2V.

Find out more at www.ovt.com.



Applications

- Smartphones
- Video Conferencing
- PC Multimedia

Product Features

- automatic black level calibration (ABLC)
- programmable controls for frame rate, mirror and flip, binning, cropping, and windowing
- support for dynamic DPC cancellation
- supports output formats: 10-bit RGB RAW, DPCM 10-8 compression
- supports horizontal and vertical subsampling
- supports typical images sizes: 4608x3456, 4608x2592, 4K2K, 1080p, 720p, and more
- standard serial SCCB interface
- up to 4-lane MIPI TX interface with speed up to 2.2 Gbps/lane
- programmable I/O drive capability
- embedded 24kbits of one-time programmable (OTP) memory for customer use
- sequential multi-frame HDR and HDR timing support
- fast contrast auto focus
- phase detection auto focus (PDAF) pixels with hardware depth calculation
- three on-chip phase lock loops (PLLs)
- programmable I/O drive capability
- built-in temperature sensor
- typical module size: 10.5 x 10.5 x 6 mm

OV16860

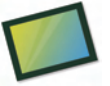

Ordering Information

- OV16860-GA5A**
(color, chip probing, 150 μm backgrinding, rev 1A (clear CFA over PD), reconstructed wafer with good die)

Product Specifications

- active array size:** 4608 x 3456
- power supply:**
 - core: 1.2V
 - analog: 2.8V
 - I/O: 1.8V
- power requirements:**
 - active: 369 mW
 - XSHUTDOWN: 3 μA
- temperature range:**
 - operating: -30°C to +85°C junction temperature
 - stable image: 0°C to +60°C junction temperature
- output formats:** 10-bit RGB RAW, DPCM 10-8 compression
- lens size:** 1/2.39"
- lens chief ray angle:** 33.1° non-linear
- input clock frequency:** 6 - 27 MHz
- scan mode:** progressive
- maximum image transfer rate:**
 - 4608x3456: 45 fps
 - 4608x2592: 60 fps
 - 2304x1728: 90 fps
 - 4K2K: 60 fps
 - 1080p: 120 fps
 - 720p: 120 fps
- sensitivity:** 520 mV/lux-sec @ 530 nm
- max S/N ratio:** 38 dB
- dynamic range:** 74.5 dB @ 16x gain
- minimum exposure interval:** 8 Tlines
- maximum exposure interval:** VTS - 12 lines
- pixel size:** 1.305 μm x 1.305 μm
- dark current:** 5 e⁻/sec @ 60°C junction temperature
- image area:** 6055.2 μm x 4551.84 μm
- die dimensions:**
 - COB: 6949.8 μm x 5549.4 μm
 - RW: 6999.8 μm x 5599.4 μm

Functional Block Diagram

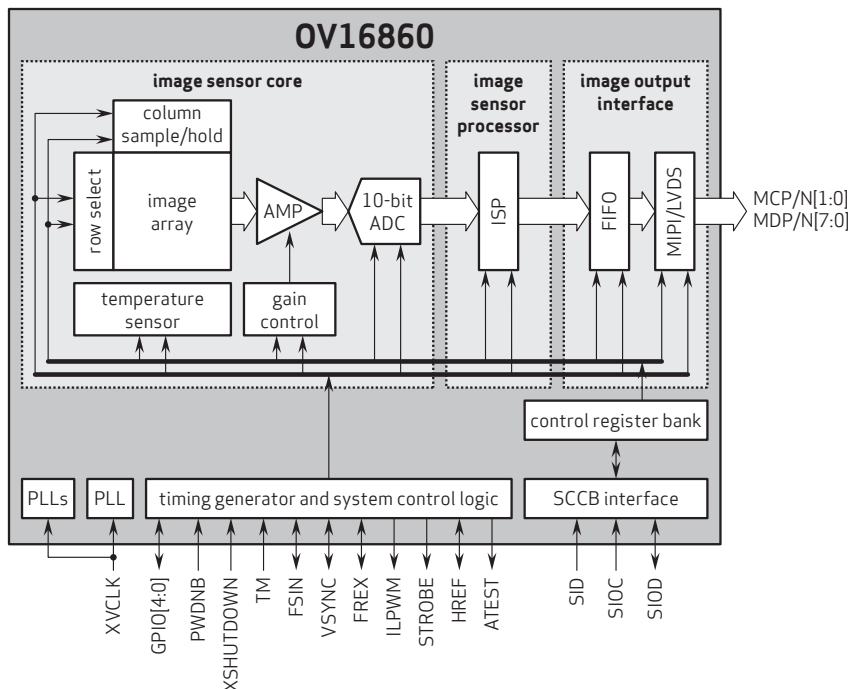

4275 Burton Drive
Santa Clara, CA 95054
USA

Tel: + 1 408 567 3000
Fax: + 1 408 567 3001
www.ovt.com

OmniVision reserves the right to make changes to their products or to discontinue any product or service without further notice. OmniVision, the OmniVision logo and PureCel are registered trademarks of OmniVision Technologies, Inc. All other trademarks are the property of their respective owners.



OmniVision