

OV10640 HDR product brief



available in
a lead-free
package

High Definition Video with Enhanced Low-Light Sensitivity and OmniHDR®-S Technology for Advanced Automotive Vision Systems

The OV10640 is the automotive industry's first image sensor to utilize backside illumination technology, enabling industry-leading sensitivity. The sensor uses OmniVision's proprietary OmniHDR®-S technology to deliver high dynamic range (HDR) of up to 120 dB in highly compact automotive-grade packages, making it an excellent solution for a broad range of advanced driver assistance systems (ADAS), including: 360-degree surround view, rear view, machine vision, blind spot detection and lane departure warning.

The sensor's 4.2-micron OmniBSI™ pixel is capable of recording highly detailed full-resolution 1.3-megapixel images and video at 60 frames per second (fps). The OV10640 leverages advanced OmniHDR®-S technology

to deliver Split Pixel and Staggered HDR, in which the scene information is sampled simultaneously rather than sequentially. This process minimizes motion artifacts and delivers superior image quality in RAW output in the most demanding and difficult lighting conditions.

The OV10640 contains industry-leading safety mechanisms to fulfill functional safety goals as required by ISO 26262. The sensor fits in a 7.4 mm x 7.2 mm a-CSP™ package and meets AEC-Q100 Grade 2 qualifications.

Find out more at www.ovt.com.



OmniVision.

Applications

- Automotive
 - 360° surround view system
 - rear view camera
 - lane departure warning/ lane keep assist
 - blind spot detection
 - night vision
- pedestrian detection
- traffic sign recognition
- occupant sensor
- camera monitoring system
- autonomous driving

Product Features

- AEC-Q100 grade 2 qualified
- support for image sizes:
 - 1280 x 1080
 - VGA
 - QVGA, and any cropped size
- OmniHDR™-S technology
- high sensitivity
- safety features
- low power consumption
- image sensor processor functions:
 - automatic exposure/gain control
 - lens correction
 - defective pixel cancelation
 - HDR combination and tone mapping
 - automatic black level correction
- supported output formats: RAW
- horizontal and vertical sub-sampling
- serial camera control bus (SCCB) for register programming
- high speed serial data transfer with MIPI CSI-2, parallel 12-bit DVP output
- external frame synchronization capability

OV10640

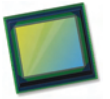

Ordering Information

- OV10640-N79Y-PF**
(color, lead-free) 78-pin a-CSP™, with DAR coating, rev 1F, packed in tray with protective film
- OV10640-N79Y-RF**
(color, lead-free) 78-pin a-CSP™, with DAR coating, rev 1F, packed in tape & reel with protective film

Product Specifications

- active array size:** 1280 x 1080
- power supply:**
 - analog: 3.14 - 3.47V
 - digital: 1.425 - 1.65V
 - DVDD: 1.7 - 1.9V
 - AVDD: 1.7 - 1.9V
- power requirements:**
 - active: 360 mW
 - standby: 100 µW
- temperature range:**
 - operating: -40°C to +105°C sensor ambient temperature and -40°C to +125°C junction temperature
- output interfaces:** 12-bit DVP, MIPI/LVDS CSI-2
- output formats:**
 - 20-bit combined RAW
 - 12-bit compressed combined RAW
 - separated 12-bit RAW
 - 2x12-bit compressed RAW
 - 16-bit log domain combined RAW
 - 3x12-bit uncompressed RAW
- input clock frequency:** 6 - 40 MHz
- lens size:** 1/2.56"
- lens chief ray angle:** 9°
- scan mode:** progressive
- shutter:** rolling shutter
- maximum image transfer rate:** 60 fps full resolution
- sensitivity:** 8.4 V/Lux-sec
- max S/N ratio:** 41.5 dB
- dynamic range:** 120 dB
- pixel size:** 4.2 µm x 4.2 µm
- image area:** 5410 µm x 4570 µm
- package dimensions:** 7430 µm x 7190 µm

Functional Block Diagram

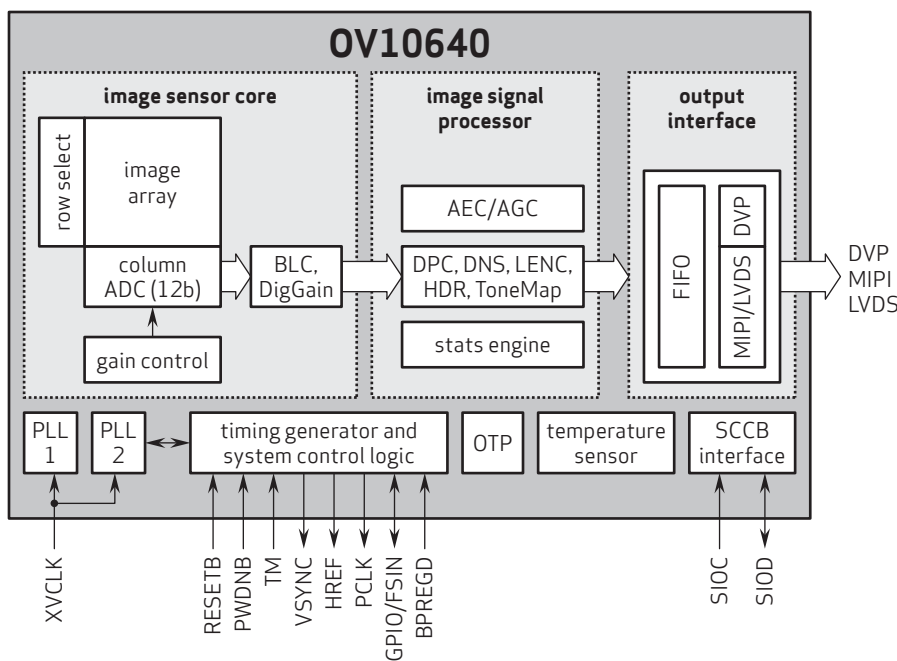

4275 Burton Drive
Santa Clara, CA 95054
USA

Tel: + 1 408 567 3000
Fax: + 1 408 567 3001
www.ovt.com

OmniVision reserves the right to make changes to their products or to discontinue any product or service without further notice. OmniVision, the OmniVision logo, and OmniHDR are registered trademarks of OmniVision Technologies, Inc. OmniBSI and a-CSP are trademarks of OmniVision Technologies, Inc. All other trademarks are the property of their respective owners.



OmniVision