



OV24A10 24-megapixel product brief



available in
a lead-free
package

OmniVision's First Image-Sensor Family with 0.9-micron Pixels Enables Best-in-Class Performance and Features for High-End Smartphones

The OV24A sensors are OmniVision's first sensors with 0.9-micron pixels. Built on PureCel[®]Plus stacked-die architecture, the sensors offer quantum efficiency performance matching that of the latest 1.0-micron pixel sensors. The combination of smaller pixels, higher resolution and improved performance makes the OV24A sensors an ideal camera solution for front- and rear-facing camera applications in high-end smartphones.

The OV24A sensor family consists of three individual products: OV24A1Q, OV24A1B and OV24A10.

The OV24A1Q, with its unique four-cell color-filter pattern, is ideal for front-facing camera applications. This sensor has an on-chip, in-pixel binning feature that captures four times more light photons than a standard 0.9-micron pixel, enabling better image quality in low-light conditions.

When used as the primary, rear-facing camera in a dual-camera configuration, the OV24A1B (monochrome) and OV24A10 (Bayer) sensors enable higher zoom ratios and higher-quality still images and video even in low-light conditions.

All three versions of the OV24A sensors are available in a 1/2.8-inch optical format and support phase detection autofocus and high dynamic range. The sensors are capable of recording ultra-high-quality video in a wide range of resolution formats, including full-resolution 24-megapixel, 4K2K, 1080p and 720p.

Find out more at www.ovt.com.



Applications

- Smartphones
- Video Conferencing
- PC Multimedia

Product Features

- automatic black level calibration (ABLC)
- programmable controls for:
 - frame rate
 - mirror and flip
 - binning
 - cropping
 - windowing
- support for dynamic DPC cancellation
- supports output formats:
 - 10-bit RGB RAW
 - DPCM 10-8 compression
- supports horizontal and vertical subsampling
- supports typical images sizes:
 - 5664 x 4248
 - 3840 x 2160
 - 1920 x 1080
 - 1280 x 720
- standard serial SCCB interface
- up to 4-lane MIPI TX interface with speed up to 2.5 Gbps/lane
- programmable I/O drive capability
- gyro interface with 3-/4-wire SPI support
- embedded 16k bits of one-time programmable (OTP) memory (4k bits reserved for customer use)
- 4-cell support (OV24A1Q without PDAF):
 - 4-cell binning
 - 4-cell full
 - 4-cell HDR timing
- sequential multi-frame HDR (OV24A10/OV24A1B)
- ZigZag HDR timing (OV24A10/OV24A1B)
- three on-chip phase lock loops (PLLs)
- programmable I/O drive capability
- built-in temperature sensor
- typical module size: 8.5 x 8.5 x -5.5 mm

OV24A10



Ordering Information

- OV24A10-GA5A-Z** (color, chip probing, 150 μm backgrinding, reconstructed wafer with good die)
- OV24A1B-GA5A-Z** (B&W, chip probing, 150 μm backgrinding, reconstructed wafer with good die)
- OV24A1Q-GA5A-Z** (color, chip probing, 150 μm backgrinding, reconstructed wafer with good die)

Product Specifications

- active array size:** 5664 x 4248
- input clock frequency:** 6 - 27 MHz
- power supply:**
 - core: 1.05V
 - analog: 2.8V
 - I/O: 1.8V
- temperature range:**
 - operating: -30°C to +85°C junction temperature
 - stable: 0°C to +60°C junction temperature
- output formats:**
 - 10-bit RGB RAW
 - DPCM 10-8 compression
- lens size:** 1/2.83"
- lens chief ray angle:** 35.1° non-linear
- maximum image transfer rate:**
 - 5664 x 4248: 30 fps
 - 3840 x 2160: 60 fps
 - 1920 x 1080: 120 fps
 - 1280 x 720: 240 fps
- maximum exposure:** VTS - 8 lines
- minimum exposure:** 8 lines
- pixel size:** 0.9 μm x 0.9 μm
- image area:** 5112 μm x 3852 μm
- dimensions:**
 - COB: 6148.8 μm x 4406.4 μm
 - RW: 6198.8 μm x 4456.4 μm

Functional Block Diagram

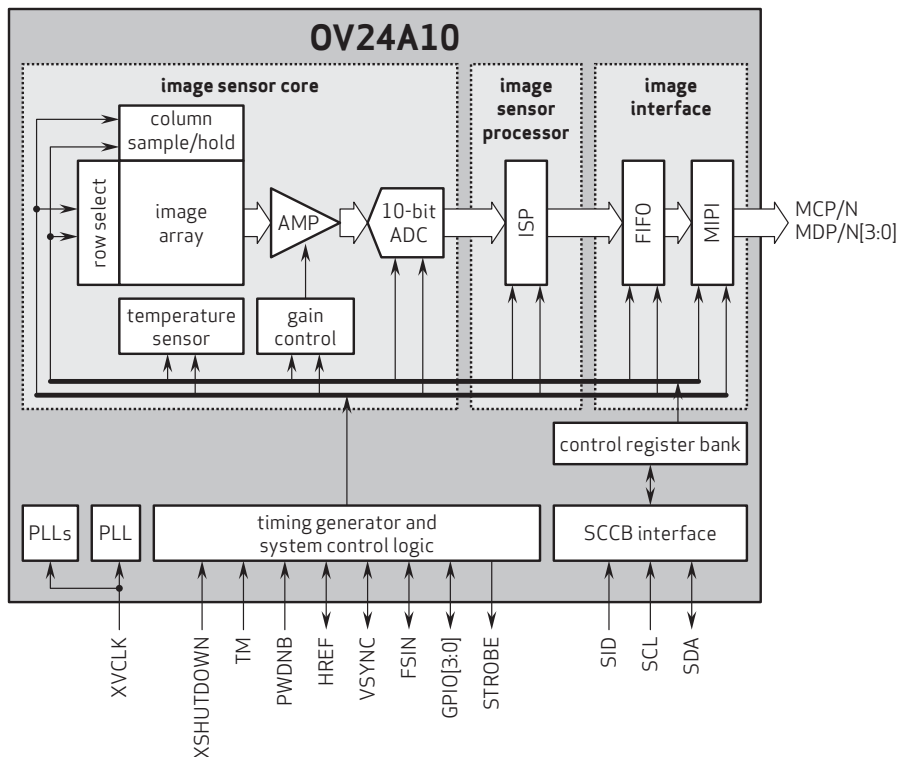

4275 Burton Drive
Santa Clara, CA 95054
USA

Tel: +1 408 567 3000
Fax: +1 408 567 3001
www.ovt.com

OmniVision reserves the right to make changes to their products or to discontinue any product or service without further notice. OmniVision, the OmniVision logo and PureCel are registered trademarks of OmniVision Technologies, Inc. All other trademarks are the property of their respective owners.



OmniVision